



1G Inspectors Guidebook

2017v1r5



Table of contents

Page 1:

Slide 2 Class 1G Goals
Slide 3 History and Intentions
Slide 4 Regulations

Page 2:

Slide 5 Classes of Licensing

Page 3

Slide 6 Steps toward licensing

Page 5

Slide 7 Documentation

Page 6

Slide 8 Changing jobs and renewal of licensing

Page 7

Slide 9 Station Rules

Page 9

Slide 10 Fleet Stations

Page 10

Slide 11 Inspectors

Page 14

Slide 12 Maintenance services at a 1G station

Page 16

Slide 13 DMV Duties

Page 17

Slide 14 Audits and Heavy Duty Diesel enforcement

Page 18

Slide 15 Overt Audits

Page 20

Slide 16 Covert Audits

Page 23

Slide 17 Penalties for Inspectors

Page 24

Slide 18 Administrative fines

Page 26

Slide 19 Owner Penalties

Page 28

Slide 21 Program Areas

Page 29

Slide 22 Private party sales, Dealer sales, Assembled Vehicles, Gray market vehicles and Engine swaps

Page 30

Slide 23 Exempt vehicles

Page 31

Slide 24 Applicants Guide and Training Checklist
Slide 26 Beginning an Inspection

Page 34

Slide 27 Main Menu

Page 35

Slide 28 Emission Inspection Menu
Slide 29 User ID

Page 36

Slide 30 Password

Page 37

Slide 31 VIN Entry

Page 38

Slide 32 VIN Entry

Page 39

Slide 33 State Messages

Page 40

Slide 34 License Plate Type Entry
Slide 35 No Plate Entry

Page 41

Slide 36 License Number Entry
Slide 37 License Entry Verification

Page 42

Slide 38 County and Zip Entry

Page 43

Slide 39 Motorhome Entry
Slide 40 GVWR Entry

Page 44

Slide 41 Odometer Entry

Page 45

Slide 42 Communications screen

Slide 43 Warning: Passing Test on File

Page 46

Slide 44 Vehicle Data Screen

Page 47

Slide 45 Exhaust Type Entry

Page 48

Slide 47 Certification Label Entry

Page 49

Slide 48 Certification Label

Page 50

Slide 50 Emissions Exception Vehicle
Form
Slide 51 First AIR Entry

Page 51

Slide 53 Air Injection Equipped Entry

Page 52

Slide 54 Tailpipe Test Start Screen

Page 53

Slide 55 Known Problem Vehicles
Slide 56 Insert Probe Screen

Page 54

Slide 57 Tach Screen

Page 55

Slide 58 High Speed mode
Slide 59 Dilution Screen

Page 56

Slide 60 Idle Speed Mode

Page 57

Slide 61 Test Complete
Slide 62 Smoke, Tailpipe Test

Page 58

Slide 66 Visible Smoke and Tampering

Slide 67 Air Injection Tamper Entry

Page 59

Slide 68 Tampering Defined
Slide 69 Application Guides

Page 60

Slide 72 EGR Tamper Entry

Page 61

Slide 74 Catalytic Converter(s) Tamper
Slide 75 Catalyst Identification

Page 62

Slide 76 Fuel Inlet Restrictor and Gas
Cap

Page 64

Slide 78 Tamper Inspection Screen

Page 65

Slide 79 Inspection Fees
Slide 80 VIR Print Screen

Page 66

Slide 81 Valid VIR

Page 67

Slide 82 Fuel Cap Failure

Page 68

Slide 83 OBD-II Testing

Page 69

Slide 84 DLC locations

Slide 85 DLC

Page 70

Slide 86 OBD II Monitoring Devices

Page 71

Slide 87 OBD II Test Start

Page 72

Slide 88 Damaged DLC

Slide 89 DLC Reason Screen

Page 73

Slide 90 Chock Wheels Screen

Slide 91 MIL Inspection

Page 74

Slide 94 Keyless Ignitions

Slide 95 MIL Light Bulb Check

Page 75

Slide 96 MIL Bulb Entry Screen

Page 76

Slide 97 Start the Engine

Slide 98 Verifying Engine Running

Page 77

Slide 99 Error Verifying Engine

Running

Slide 100 OBD II Readiness Monitors

Page 78

Slide 101 MIL Command Status

Page 79

Slide 102 DTC Display

Page 80

Slide 103 OBD II and Smoke

Slide 104 Smoke Entry

Page 81

Slide 105 Test Fees

Page 82

Slide 106 End of OBD II Test

Page 83

Slide 107 Reject VIR

Slide 108 Fail VIR

Slide 109 Failing Test

Slide 110 Waivers

Page 86

Slide 111 Rejects

Slide 112 Alternative Registration

Renewal Services

Slide 113 and 114 Important Contacts

Page 87

Slide 115 Closing Statement

Slide 116 and 117 Test Taking Tips

Page 89

Slide 118 Testing Rules

Page 90

Appendix

Slide 2 Class 1G Goals

You are expected to learn licensing procedures and test procedures; The Rules and Regulations that govern emission testing in Nevada, including: The Clean Air Act of 1970, part 51, Chapter 1, Title 40; NRS 445B.700–845; NAC 445B.400–735; The Nevada Register.

Your goal is to learn the Licensing procedures, Test procedures, and the Rules and regulations.

The workbook is keyed to slide numbers in this presentation and therefore, to prevent confusion, you must refer questions to the slide number. It is an open-book test.

No other notes or materials not provided in this class may be used during the written examination.

Slide 3 History and Intentions

The United States Congress passed the original Federal Clean Air Act in 1970. This act set air quality standards for the entire nation. Any areas that could not meet these standards were required to implement and maintain an emission program designed to achieve reduction in air pollution to meet the standards. The plan for the emissions program is called the State Implementation Plan or SIP. The main reasons for an Emission Inspection and Maintenance Program otherwise known as the I/M Program in Nevada are to:

- 1) Improve the air quality.
- 2) Maintain the air quality improvement that has already been achieved, and
- 3) Retain Federal funding for Nevada Highways and other Federally funded projects.

Slide 4 Regulations

The regulations for Vehicle Emission Inspection are found in the CAA, NRS, NAC, and Nevada Register.

CAA is the Federal Clean Air Act of 1970

NRS is the Nevada Revised Statutes and are the current codified laws of the State of Nevada and are a compilation of all legislation passed by the Nevada Legislature. These are the law.

NAC is the Nevada Administrative Code and is the codified, administrative regulations of the Executive Branch, this contains the details of how to accomplish the requirements of the NRS. These carry the force of law.

The Nevada Register is a compilation of proposed, adopted, emergency and temporary administrative regulations. These contain adopted regulations that have not yet been published into the NAC but are in force and also carry the force of law, also proposed regulations that are awaiting approval or rejection. If the file number is followed by an A, the regulation has been approved and carries the force of law.

SIPs are State Implementation Plans. This document lists exactly how and what the state proposes to do to bring the air quality into compliance with federal regulations.

NRS, NAC, & the Nevada Register are available on the web at:

<http://leg.state.nv.us/law1.cfm>

Slide 5 Classes of Licensing

There are 2 classes of emission inspector licenses in Nevada, Class 1 and Class 2.

There are 2 ratings, G and/or D, G for Gasoline, D for Diesel.

A Class 1 inspector is licensed by the department **only** to test exhaust emissions.

A Class 2 approved inspector is licensed by the department to test exhaust emissions and to diagnose, repair and adjust devices for the control of exhaust emissions, gasoline only.

Nevada does not regulate the repair on failed diesel emission tests, so there is no 2D license, it is simply a D license.

NRS 445B.705 “Approved inspector” defined. “Approved inspector” means a person licensed by the Department of Motor Vehicles to inspect motor vehicles and devices for the control of pollution for an authorized station or authorized inspection station.

NAC 445B.4096 “Class 1 approved inspector” defined. ([NRS 445B.785](#)) “Class 1 approved inspector” means an approved inspector who is licensed by the Department only to test exhaust emissions.

NAC 445B.4098 “Class 2 approved inspector” defined. “Class 2 approved inspector” means an approved inspector who is licensed by the Department to test exhaust emissions and to diagnose, repair and service devices for the control of exhaust emissions.

NAC 445B.460 Test station: License required to operate; expiration of license; ratings; performance of certain services; prohibited acts; location.

(a) A “G” rating if it will be testing the exhaust emissions of gasoline-powered motor vehicles. A test station with a “G” rating shall, when conducting inspections of motor vehicles subject to the provisions of [NAC 445B.580](#), use an exhaust gas analyzer that complies with the equipment specifications published by the Department for this rating and at least one approved inspector who has a “G” rating to perform the exhaust emissions tests.

(b) A “D” rating if it will be testing the exhaust emissions of light-duty diesel motor vehicles. A test station with a “D” rating shall, when conducting inspections of motor vehicles subject to the provisions of [NAC 445B.589](#), use a dynamometer and a smoke opacity meter that comply with the requirements of [NAC 445B.587](#) and at least one approved inspector who has a “D” rating to perform the exhaust emissions tests.

Slide 6 Steps toward licensing

All licensing of Inspectors is handled through the Emission Lab in your area.

In order to become licensed as a class 1 or class 2 inspector you must attend and complete a rules and regulations class conducted by the Department, and pass the written examination, with a score of 80% or higher.

You must also complete an outside training course in basic emission control or be currently ASE certified in A-8, Automotive Engine Performance or L-1, Advanced Automotive Engine Performance. Also you must obtain and submit a certificate of competence issued by the manufacturer of an exhaust gas analyzer approved by the Department, indicating your ability to adjust and operate the equipment or demonstrate proficiency in analyzer operation and maintenance to the Departments Emission Lab with a score of 80% or higher at the time of the practical examination.

You must then pass the Practical Demonstration Examination **without error**.

The practical demonstration is comprised of performing two emission inspections at the emission lab, one tailpipe and one OBD, just as you would in the field.

In the applicants guide and training checklist you'll find a list of all the information that you're required to know for the Practical exam.

It lists exactly what's expected of you.

If you fail either the practical or written examinations for the first time you must wait 7 days before a second attempt.

If you fail for a second consecutive attempt **or more**, you must submit proof to The Department that you have successfully completed additional training that is approved or conducted by The Department.

NAC 445B.485 Prerequisites to licensing.

1. The Department will not license a person as a class 1 approved inspector unless he has demonstrated his qualifications and ability to test motor vehicles to its satisfaction by:

(a) Submitting an application, on a form provided by the Department;

(b) Submitting a certificate of competence issued by the manufacturer of an exhaust gas analyzer approved by the Department, indicating his ability to adjust and operate the equipment required to obtain the rating or ratings for which he is applying pursuant to [NAC 445B.498](#), or by demonstrating to the Department his ability to adjust and operate such equipment; and

(c) Successfully:

(1) Completing a training course or courses for a license as a class 1 approved inspector which was conducted or approved by the Department, or equivalent training approved by the Department, for the particular rating or ratings for which he is applying;

(2) Completing a written test for a license as a class 1 approved inspector which was prepared by the Department for the particular rating or ratings for which the person is applying with a score of at least 80 percent; and

(3) Performing a practical demonstration of the procedures for testing prescribed by the Department.

2. The Department will not license a person as a class 2 approved inspector unless he has demonstrated his qualifications and ability to test motor vehicles and to diagnose, repair and service devices for the control of exhaust emissions to its satisfaction by submitting an application, on a form provided by the Department, which establishes that he has, within the last 12 months, satisfied the requirements set forth in paragraphs (b) and (c) of subsection 1 for a license as a class 1 approved inspector for the particular rating or ratings for which the person is applying and:

(a) Successfully completed a written test for a license as a class 2 approved inspector which was administered by the Department for the particular rating or ratings for which the person is applying with a score of at least 80 percent; or

(b) Submitted current certification from the National Institute for Automotive Service Excellence as an advanced engine performance specialist. The certification must remain valid throughout the applicant's 24-month period of licensure as a class 2 approved inspector.

3. The Department will investigate each applicant to determine his fitness.

NAC 445B.486 Examination of applicants for licensing. 1. The Department will establish written tests for the licensing and rating of class 1 approved inspectors and class 2 approved inspectors.

2. An applicant taking such a test must show that he has completed the course, courses or equivalent training required pursuant to [NAC 445B.485](#) for the rating or ratings for which he is applying.

3. An applicant who fails to pass the written test or practical demonstration required for a license as a class 1 approved inspector must wait 7 calendar days before he may retake the test or demonstration.

4. If an applicant fails two or more consecutive written tests or practical demonstrations required for a license as a class 1 approved inspector, he must, before he may retake the test or demonstration, submit proof to the Department that he has, after failing the tests or demonstrations, successfully completed an additional training course which is conducted or approved by the Department.

5. If an applicant fails to pass the written test required for a license as a class 2 approved inspector, he must, before he may retake the test, submit proof to the Department that he has, after failing the test, completed a training course regarding the diagnosis, repair and servicing of devices for the control of exhaust emissions which was conducted or approved by the Department for the rating or ratings for which he is applying.

Slide 7 Documentation

Documentation must be correctly and completely filled out and submitted along with a valid picture ID to the Lab to become licensed.

You must submit an **Analyzer Certificate of Competence issued by the manufacturer of an exhaust gas analyzer approved by the Department, indicating your ability to adjust and operate the equipment, or** demonstrate to the Department your ability to adjust and operate such equipment.

The other documents you must submit are; a **Personal History Questionnaire**, completed and signed by the applicant. Be aware that a license can be denied, suspended or revoked for submitting false information, including inaccurate or misleading information, or concealing any material fact on the application or supporting documents. This is contained in NAC 445B.489; a **Child Support Information Form**, completed and signed by the applicant; a **Licensee Acknowledgement form**, completed and signed by the applicant; two photographs of applicant, full face, shoulders and above, no sunglasses or hats,

etc.; an **Authorization for Release of Information form**, completed and signed by the applicant; a completed **Certificate of Employment**, only signed by the employer.

Once you have passed both the written examination and the practical demonstration examination, you must pay the fees required.

All of YOUR signatures must be witnessed by DMV staff, do not sign them until instructed to by the DMV Emission Technician.

FEES:

The fee for an Initial or renewal license is \$25.00, duplicate licenses or licenses for additional locations are \$10.00 each and transfer to a different location is \$10.00 each

Slide 8 Changing jobs and renewal of licensing

In order to change a place of employment or add an additional place of employment you must submit in person, a new **Certificate Of Employment** signed by the new employer, to the local Emission Lab along with the necessary photographs, and then follow the instructions given to you by the DMV Emission Technician.

Licenses are valid for a two-year period.

To renew either a 1G or D, you must attend and complete the rules and regulations course conducted by the DMV then pass the written examination with a score of 80% or higher.

NAC 445B.497 Requirements for renewal of license.

1. If an approved inspector wishes to renew his license, he must, within the 3 months before its expiration and before it is reissued, successfully:

(a) Complete a course for the renewal of his license which is approved or developed and conducted by the Department for the particular class and rating or ratings the approved inspector is attempting to renew; and

(b) Complete a written test, with a score of at least 80 percent, which is approved or prepared by the Department for the particular class and rating or ratings the approved inspector is attempting to renew. Before the holder of a license as a class 2 approved inspector may take a test for the renewal of that class of license, he must submit to the Department proof that he has, after the initial issuance or last renewal of his license, whichever occurred last, successfully completed a course that includes updates on the latest technology available regarding the diagnosis, repair and servicing of devices for the

control of exhaust emissions which was conducted or approved by the Department for the rating or ratings the approved inspector is attempting to renew.

2. An approved inspector who fails to attain a score of 80 percent on the written examination required by subsection 1 for the renewal of a license as:

(a) A class 1 approved inspector may not take the examination again within 7 calendar days after the date of the first examination. If an approved inspector fails two or more consecutive written examinations for the renewal of a license as a class 1 approved inspector, he must submit proof to the Department that he has, after failing the examinations, successfully completed an additional course conducted or approved by the Department before he may retake the examination.

(b) A class 2 approved inspector must, before he may retake the examination, submit proof to the Department that he has, after his failure of that examination, successfully completed a course regarding diagnosis, repair and servicing of devices for the control of exhaust emissions which was conducted or approved by the Department for the rating or ratings the approved inspector is attempting to renew.

3. If the license of an approved inspector remains inactive, revoked or in expired status for 1 year or longer, the approved inspector shall be deemed to be a new applicant and must again comply with all applicable requirements concerning training and examinations.

Slide 9 Station Rules

Display of licenses; all Emission Test station and Inspectors licenses must be displayed in an area frequented by the public at a height of between 4 and 6 feet from the floor.

Hours; Business hours must be posted in a location frequented by customers.

The minimum emission station business hours are from 8:00 AM to 5:00 PM, Monday through Friday. These are normal business hours and must be followed.

For a station being operated by a single person, a note indicating **when the Inspector will return** must be posted at the station during any instance the test station is closed during normal business hours. (NAC445b.480)

Inspector; the station must employ, full time, at least one 1G or 2G Inspector.

Inspections; the station must inspect all motor vehicles requiring an inspection that are presented at the facility for an inspection, unless there is a safety or dilution issue. **No pre-testing**. All failing VIRs must be accompanied by a current list of 2G stations

Information sources; stations are required to have available for their Inspectors; NRS and NAC sections pertaining to Vehicle Emission testing (445B); Emission Control Application guides or equivalent information sources; an Analyzer manual supplied by the manufacturer.

NAC 445B.470 Test station: Display of licenses; availability of reference information.

1. The license to operate a test station and all licenses issued to approved inspectors must be displayed in a conspicuous place under glass or other transparent material at a height of not less than 4 feet and not more than 6 feet within an area of the test station that is accessible to and frequented by customers.

2. Except as otherwise provided in subsection 3:

(a) A test station shall keep the operator's manual for its exhaust gas analyzer readily available to the approved inspector.

(b) A test station shall have readily available to the approved inspector a reference manual or equivalent information stating the emissions devices which are required by state and federal law to be installed on each type of motor vehicle that is inspected. The owner of the test station or his designee shall, upon the request of a representative of the Department, demonstrate the availability of the reference manual or equivalent information by accessing the manual or information.

(c) An authorized station or class 2 fleet station shall have readily available to the class 2 approved inspector reference information in the form of printed or electronic media explaining the operation and maintenance of the emissions devices which are required by state and federal law to be installed on each type of motor vehicle. The owner of the test station or his designee shall, upon the request of a representative of the Department, demonstrate the availability of the reference information:

(1) If a telephone or facsimile transmission is not required to access the reference information, by accessing the reference information; and

(2) If the reference information is accessible only through the use of a telephone or facsimile transmission, by using the telephone or facsimile transmission to obtain and provide to the representative of the Department one copy of the reference information.

3. A fleet station is not required to maintain the specifications or instructions of the manufacturer for any motor vehicles other than those motor vehicles used and serviced by the fleet station.

NAC 445B.460 Test station: License required to operate; expiration of license; ratings; performance of certain services; prohibited acts; location

1. No person may engage in the business of issuing evidence of compliance unless he holds a current license to operate a test station at an established place of business and holds one or both of the ratings set forth in subsection 3.

3. A test station must obtain from the Department:

(a) A "G" rating if it will be testing the exhaust emissions of gasoline-powered motor vehicles. A test station with a "G" rating shall, when conducting inspections of motor vehicles subject to the provisions of [NAC 445B.580](#), use an exhaust gas analyzer that complies with the equipment specifications published by the Department for this rating

and at least one approved inspector who has a “G” rating to perform the exhaust emissions tests.

NAC 445B.480 Test station: Requirements concerning business hours 1. A test station shall post and adhere to regular business hours and test any motor vehicle presented at its facility during those hours, except as otherwise provided in [NAC 445B.478](#) or unless the motor vehicle is rejected for reasons of safety.

2. For the purposes of this section, regular business hours are Monday through Friday from 8 a.m. to 5 p.m. except on the holidays set forth in [NRS 236.015](#).

3. For an authorized station or an authorized inspection station operated by a single employee, a notification indicating at what time the employee will return must be posted at the test station for any instance of business closure.

Slide 10 Fleet Stations

A fleet station license may be issued to an owner or lessee of a fleet of 25 or more vehicles.

Fleet stations must meet all of the same requirements applicable to test stations in general with the following exceptions:

A Fleet station is not required to maintain specifications or manufacturers repair information for any motor vehicles other than the motor vehicles in it's fleet.

A Fleet station may only inspect vehicles in it's fleet, or those from it's fleet which are sold to the public.

A fleet station may not inspect vehicles that are not in it's fleet of owned or leased vehicles. No privately owned vehicles.

NAC 445B.478 Fleet station: Licensing; powers and duties. 1. A license for a class 1 fleet station or class 2 fleet station may be issued to an owner or lessee of a fleet of 25 or more motor vehicles.

2. Except as otherwise provided in [NAC 445B.400](#) to [445B.735](#), inclusive, a fleet station must meet all the requirements applicable to test stations in general.

3. A fleet station may inspect only those motor vehicles which constitute its fleet and may issue evidence of compliance for such motor vehicles which are sold to the public.

Slide 11 Inspectors

All 1G Inspectors are expected to understand the maintenance and operation of the analyzer.

All 1G Inspectors are expected to understand how to perform a vehicle tailpipe inspection correctly, completely, and safely.

All 1G Inspectors are expected to understand how to perform a vehicle OBD inspection correctly, completely, and safely.

All 1G Inspectors are expected to determine whether an emission inspection is required or not.

All 1G Inspectors are expected to inspect any motor vehicle that requires an inspection for registration purposes, that is presented at the station, unless there is a safety problem or exhaust dilution occurs.

All 1G Inspectors are expected to never pre-test, this is a violation of regulation.

All 1G Inspectors are expected to follow all of the screen prompts on the analyzer, this is regulation.

All 1G Inspectors are expected to determine correctly the classification of each vehicle type, including GVW, light or heavy duty, Motor home.

All 1G Inspectors are expected to determine correctly the year, make and model of each vehicle.

All 1G Inspectors are expected to determine what equipment the state of Nevada requires to be present and be able to demonstrate the availability and use of any emission information source used at the station at which they are employed when asked by a State of Nevada Emission Technician.

All 1G Inspectors are expected to locate and determine if the required devices are present and appear functional.

All 1G Inspectors are expected to understand NAC 445B.400 – 735, the regulations pertaining to emission from engines.

All 1G Inspectors are expected to guard their Password.

All 1G Inspectors are expected to keep themselves educated with past, current, and future emission technology in the automotive industry.

All 1G Inspectors are expected to notify the lab in person within ten days if they leave the employ of any station.

All 1G Inspectors are expected to have a 2G inspector verify your emission repairs if employed at a 2G station.

NAC 445B.480 Test station: Requirements concerning business hours. 1. A test station shall post and adhere to regular business hours and test any motor vehicle presented at its facility during those hours, except as otherwise provided in [NAC 445B.478](#) or unless the motor vehicle is rejected for reasons of safety.

NAC 445B.580 Inspection of vehicle: Procedure for certain vehicles with model year of 1995 or older and heavy-duty vehicles with model year of 1996 or newer 1. Except as otherwise provided in subsection 4, the provisions of this section apply to inspections of:

- (a) All motor vehicles with a model year of 1968 to 1995, inclusive; and
- (b) With regard to motor vehicles with a model year of 1996 or newer, all heavy-duty motor vehicles.

2. After the owner or operator of a motor vehicle subject to the provisions of this section requests an inspection, an approved inspector shall follow the sequence of prompts displayed by the exhaust gas analyzer when conducting the inspection. While the vehicle is at normal operating temperature, the inspector shall connect the exhaust gas analyzer to the vehicle following the sequence of instructions programmed into the analyzer. The probe of the analyzer must be placed in the exhaust pipe of the vehicle. With the engine speed increased to 2,500 revolutions per minute, a steady level of carbon monoxide and hydrocarbons must be recorded by the analyzer. The engine speed must be returned to idle and a steady level of carbon monoxide and hydrocarbons must be recorded. If the vehicle is equipped with dual exhaust pipes, a test must be completed on both exhaust pipes and the average level of carbon monoxide and hydrocarbons must be recorded when the engine speed is increased to 2,500 revolutions per minute and when the engine speed is returned to idle.

3. The inspector shall visually inspect:

- (a) The exhaust system to determine whether or not there is smoke when idling and at 2,500 revolutions per minute; and
- (b) The engine to determine whether or not there are blowby gases from the crankcase when idling and at 2,500 revolutions per minute.

4. The inspector shall:

- (a) Visually inspect:
 - (1) All motor vehicles subject to the provisions of this section to determine the presence of a properly installed gas cap; and
 - (2) Each motor vehicle with a model year of 1981 to 1995, inclusive, and, with regard to motor vehicles with a model year of 1996 or newer, each heavy-duty motor vehicle, to determine the presence of an exhaust gas recirculation system, catalytic converter, air injection system and fuel inlet restricter, and to determine whether that

equipment appears to be operating in accordance with the specifications of the manufacturer of the vehicle; and

(b) Enter the results of the visual inspection into the analyzer.

5. The inspector shall complete each test and issue a vehicle inspection report indicating whether or not the vehicle passes the inspection.

6. The inspector shall issue a vehicle inspection report indicating that the vehicle did not pass the inspection if:

(a) The emissions from the vehicle exceed the maximum levels for carbon monoxide or hydrocarbons, or both, as prescribed in [NAC 445B.596](#);

(b) Smoke or blowby is visible; or

(c) The vehicle does not meet the requirements of [NAC 445B.579](#).

7. If a motor vehicle subject to the provisions of this section passes all portions of an inspection but has an improper gas cap or no gas cap, the owner or operator of the motor vehicle shall obtain a gas cap which is in accordance with the specifications of the manufacturer of the vehicle. The inspector shall inspect the new gas cap and certify its presence in a manner prescribed by the Department, and sign and date the failing vehicle inspection report beneath the gas cap tamper description. Such a vehicle inspection report may be used as evidence of compliance.

NAC 445B.5805 Inspection of vehicle: Procedure for light-duty vehicles with model year of 1996 or newer.

1. The provisions of this section apply to inspections of light-duty motor vehicles with a model year of 1996 or newer.

2. After the owner or operator of a motor vehicle subject to the provisions of this section requests an inspection, the inspector shall:

(a) Turn the ignition switch to the off position for at least 12 seconds.

(b) Locate the data-link connector for the vehicle and connect the test equipment.

(c) Visually inspect the operation of the malfunction illumination light while turning the ignition switch to the run position with the engine off.

(d) Start the vehicle and, with the engine running, establish communication with the certified on-board diagnostic system installed in the vehicle.

(e) Visually inspect the vehicle to determine whether the malfunction illumination light is commanded on.

(f) Review the emission readiness code status.

(g) Retrieve all data trouble codes that are present.

3. The inspector shall complete each test and issue a vehicle inspection report indicating whether or not the vehicle passes the inspection.

4. The inspector shall issue a vehicle inspection report indicating that the vehicle did not pass the inspection if:

(a) The vehicle has a malfunction illumination light that fails to illuminate during a visual inspection while the ignition switch is turned to the run position with the engine off;

(b) The vehicle has its malfunction illumination light commanded on continuously;

(c) The vehicle has a data-link connector that is missing, has been tampered with or is inoperable, including related electrical circuitry;

- (d) There is no serial data communication from the certified on-board diagnostic system installed in the vehicle;
- (e) The vehicle has a model year of 2001 or newer and has more than one unset readiness indicator;
- (f) The vehicle has a model year of 1996 to 2000, inclusive, and has more than two unset readiness indicators; or
- (g) Smoke is visible in the exhaust emissions from the vehicle with the engine speed at idle.

NAC 445B.4983 Issuance of access code to approved inspector; use of access code and identification number.

1. In addition to the identification number assigned to each approved inspector, the Department will issue to each approved inspector a unique and confidential access code. The access code will enable the approved inspector to activate, access and input data into the exhaust gas analyzer located at the test station where he is employed.

2. An approved inspector, including, without limitation, the operator of a test station, shall not willfully or negligently allow any person to use his identification number or access code to:

- (a) Activate, access or input data into the exhaust gas analyzer; or
- (b) Issue a certificate of compliance.

NAC 445B.501 Report of change in place of employment or termination of employment.

Every inspector approved by the Department shall report in writing to the Department every change in his place of employment and any termination of his employment within 10 days after the date when the change or termination occurred.

NAC 445B.475 Authorized station or class 2 fleet station: Requirements for employees.

1. An employee of an authorized station or class 2 fleet station shall not perform any testing of exhaust emissions or perform any diagnosis, repair or servicing of devices for the control of exhaust emissions unless he is licensed as a class 1 approved inspector or class 2 approved inspector.

2. Each authorized station and class 2 fleet station shall have a class 2 approved inspector on the premises during all hours of business. A class 1 approved inspector employed by an authorized station or class 2 fleet station may diagnose, repair and service a device for the control of exhaust emissions only if his work is inspected and approved in writing by a class 2 approved inspector.

Slide 12 Maintenance services at a 1G station

A 1G test-only Authorized Inspection Station is allowed to do emission testing and very limited types of engine maintenance.

On any vehicle, the station may; change the engine oil; replace the oil filter, air filter, fuel Filter, any external conventional or serpentine accessory drive belt and any cooling system hose

On 1980 and older vehicles only, that have not failed their most recent emission test performed in this State, an Authorized Inspection Station (1G) may; replace the spark plugs, replace the secondary ignition cables or spark plug wires, replace the distributor caps and/or rotors, replace the points and/or condensers; adjust the point dwell and initial ignition timing of the engine, adjust the settings for idle speed only if those settings are accessible, if these settings are sealed or capped from the factory they may not be adjusted.

An Authorized Inspection Station (1G) may also service a fuel injection system but only by using a method that utilizes a cleaning solvent for the fuel system that is registered as a fuel additive with the USEPA and Introduces the cleaning solvent into the fuel tank and no other portion of the vehicle's fuel system or air intake system. It cannot involve the dismantling, removal or adjustment of any portion of the fuel system or air intake system other than the fuel inlet cap.

An Authorized Inspection Station (1G) can not advertise any emission testing on 1980 and older vehicles in conjunction with any of these services.

An Authorized Inspection Station (1G) should call the Emissions Lab to verify that the vehicle has not failed it's most recent emission test in Nevada before proceeding with any service listed in this Section. It is a violation for a An Authorized Inspection Station (1G) to perform any emission related repairs on any vehicle that has failed it's most recent emission test in this State.

On a vehicle with a model year of 1981 or newer, the An Authorized Inspection Station (1G) shall not perform any service or diagnostic action which has a direct effect on data stored in the vehicle computer which monitors how the engine, transmission or emission control system is operating, including, without limitation,

the clearing of diagnostic trouble codes relating to the engine, transmission or emission control system. This includes also replacing or servicing of the battery if the result is the clearing of diagnostic trouble codes.

NAC 445B.460 Test station: License required to operate; expiration of license; ratings; performance of certain services; prohibited acts; location.

1. No person may engage in the business of issuing evidence of compliance unless he holds a current license to operate a test station at an established place of business and holds one or both of the ratings set forth in subsection 3.

2. A license that:

(a) Was issued for a test station before September 25, 1998, expires on September 30 of each calendar year.

(b) Is issued on or after September 25, 1998, expires 1 year after the last day of the month in which the license was originally issued.

3. A test station must obtain from the Department:

(a) A "G" rating if it will be testing the exhaust emissions of gasoline-powered motor vehicles. A test station with a "G" rating shall, when conducting inspections of motor vehicles subject to the provisions of [NAC 445B.580](#), use an exhaust gas analyzer that complies with the equipment specifications published by the Department for this rating and at least one approved inspector who has a "G" rating to perform the exhaust emissions tests.

(b) A "D" rating if it will be testing the exhaust emissions of light-duty diesel motor vehicles. A test station with a "D" rating shall, when conducting inspections of motor vehicles subject to the provisions of [NAC 445B.589](#), use a dynamometer and a smoke opacity meter that comply with the requirements of [NAC 445B.587](#) and at least one approved inspector who has a "D" rating to perform the exhaust emissions tests.

4. A facility which holds a license as an authorized inspection station or class 1 fleet station:

(a) Except as otherwise provided in this subsection, may test exhaust emissions but shall not, unless specifically authorized by the Commission, perform any installation, repair, diagnosis or adjustment to any component or system of a motor vehicle that affects exhaust emissions.

(b) May:

(1) Change oil;

(2) Replace an oil filter, air filter, fuel filter, external conventional or serpentine accessory drive belt or cooling system hose; and

(3) With regard to a vehicle with a model year of 1980 or older which has not failed its most recent exhaust emissions test administered in this State:

(I) Replace the spark plugs, secondary cables for the spark plugs, distributor cap, rotor, points or condenser of the vehicle; and

(II) Adjust the dwell and initial ignition timing of the engine of the vehicle, and the settings for idle speed if those settings are accessible.

(c) With regard to a vehicle with a model year of 1981 or newer, shall not perform any service or diagnostic action which has a direct effect on data stored in the vehicle

computer which monitors how the engine, transmission or emission control system is operating, including, without limitation, the clearing of diagnostic trouble codes relating to the engine, transmission or emission control system.

5. An authorized inspection station shall not advertise any services which it provides for the testing of exhaust emissions with any services described in subparagraph (3) of paragraph (b) of subsection 4 that the authorized inspection station also provides.

6. A person licensed to operate a test station shall not own or hold any ownership interest in any business which manufactures, sells, repairs, rents or leases exhaust gas analyzers approved by the Department for the testing of exhaust emissions.

7. A person or business which manufactures, sells, repairs, rents or leases exhaust gas analyzers approved by the Department for the testing of exhaust emissions shall not own or hold any ownership interest in any business licensed to operate a test station.

8. An authorized inspection station or class 1 fleet station must not be located immediately adjacent to any business which performs any installation, repair, diagnosis or adjustment of a component or system of a motor vehicle that affects exhaust emissions unless:

- (a) The facility for the station is physically separated from the adjacent facility;
- (b) The facility for the station and the adjacent facility have separate entrances for customers and do not share any common doors or entries between the facilities;
- (c) The adjacent facility has no access to the physical space in which testing occurs at the facility for the station;
- (d) No employee of the adjacent facility is employed by the station; and
- (e) The facility for the station and the adjacent facility have separate mailing addresses.

9. A facility that holds a license as an authorized inspection station or class 1 fleet station may perform the servicing of a fuel injection system only by using a method that:

- (a) Utilizes a cleaning solvent for the fuel system that is registered as a fuel additive with the United States Environmental Protection Agency in accordance with the requirements of 40 C.F.R. Part 79;
- (b) Introduces the cleaning solvent into the fuel tank and no other portion of the vehicle's fuel system or air intake system; and
- (c) Does not involve the dismantling, removal or adjustment of any portion of the fuel system or air intake system other than the fuel inlet cap.

Slide 13 DMV Duties

Among the DMV Emission Technician duties are educating inspectors in the classroom and in the field, at emission stations, this is known as Field Remedial Training.

DMV Emission Technician duties include performing challenge tests at the Emission Lab, issuing waivers, **Only the Emissions Lab can issue a waiver.**

testing inspectors with the written examinations, initial licensing and renewal, and the Practical Examination conducted at the emissions lab.

The Emission Technicians also referee smoking vehicle failures and reports, so always refer all vehicles with smoking vehicle letters to the emissions lab.

The Emission Technicians conduct overt audits, this is when you know they are there, and Covert audits this is when you do not know they are there.

The Emission Technicians verify engine changes and issue engine swap documents.

Also The Emission Technicians are a primary contact for dissemination of Emission Program information to the public and Government agencies.

Slide 14 Audits and Heavy Duty Diesel enforcement

Overt Audits:

In an overt audit Emission Technicians openly monitor activities at emission stations.

In the first sixty days after receiving a new Inspectors license and at any time through out your career as a licensed emission inspector you may have field remedial training. This is when a DMV Emission Technician will observe you doing emission tests on customer's vehicles at your place of employment. Any problems that are observed are documented on a performance report, and reviewed with the inspector as well as the manager or owner. This performance report will be signed and dated by the Inspector and the Emission Technician and placed in the inspector's permanent file.

At any time that a DMV Emission Technician is there, any violation or potential violation of State or Federal laws or regulations that are noted or observed may trigger an undercover run or Covert Audit

Among other DMV Emission Technician Duties are conducting Nevada Dealer Emission Audits. This is where inspections at dealer locations to verify compliance with the emission regulations and other regulations pertaining to dealer sales are conducted.

There are three (3) HD diesel enforcement teams in the state, one in the Reno area and two in the Las Vegas area. They inspect heavy duty diesel vehicles at roadside test areas and also perform on road enforcement. They observe heavy duty vehicles that are actually on the road and stop and inspect those that appear to be emitting excessive smoke. Their visual observations are very accurate but the actual test is done by machine and is a snap throttle test, the SAE J1667 test procedure.

NAC 445B.575 Device to control pollution: General requirement; alteration or modification. ([NRS 445B.210](#), [445B.770](#), [445B.785](#))

1. Except as otherwise provided in this section, a person shall not:
 - (a) Sell, offer to sell, display, operate or leave standing any motor vehicle which is required by state or federal law to be equipped with a device for the control of pollution unless the device is correctly installed and in operating condition.
 - (b) Disconnect, alter or modify any such required device.
2. Except for [NAC 445B.5815](#), the provisions of subsection 1 and [NAC 445B.576](#) to [445B.582](#), inclusive, do not apply to an alteration or modification of a motor vehicle to use fuel other than gasoline or diesel fuel where the alteration or modification is effected without violating existing federal and state standards for the control of exhaust emissions.
3. The provisions of subsection 1 do not apply to a wholesale transaction between licensed dealers of motor vehicles.
4. The Department may inspect a licensed dealer of motor vehicles to determine compliance with this section. Such inspections must be conducted in accordance with subparagraph (2) of paragraph (a) of subsection 4 of [NAC 445B.580](#).
5. As used in this section, a “device for the control of pollution” includes, without limitation, a gasoline cap which meets the specifications of the manufacturer of the motor vehicle and seals the neck or pipe of the fuel filler.

Slide 15 Overt Audits

DMV Emission Technicians will perform an overt (meaning open, you know we’re there) audit at least once a month.

All Test Stations must have on display the station license, the business license, the inspectors licenses, an outdoor metal emission sign, and an indoor information placard.

All Test Stations must have a copy of the pertinent sections of NRS and NAC (the blue rules & regulations book), available for use by the approved inspectors,

the analyzer operators manual, available for use by the approved inspectors, and a current emission control systems application manual available for use by the approved inspectors.

All 2G stations must have repair and maintenance information available in the form of printed or electronic media for models 1968 to within two years of the current year for use by the approved inspectors.

All licensed technicians employed by the station must be able to demonstrate the use of the reference material and electronic media.

Any emission station that uses a facsimile service to satisfy this requirement will be required to obtain at least one copy of any sample information when requested by the DMV Emission Technician.

The DMV Emission Technician will perform an audit of the emission analyzer. It is an overall inspection to make sure the analyzer meets manufacturers specifications, with all analyzer equipment present and functional, including leak checks on both dual and single probes.

A gas audit will be conducted at least once a quarter.

Any problems that are found that cannot be corrected by the station during the audit will result in the analyzer being locked out until the repairs are made. Once the repairs are complete contact the Emission Lab. An Emission Technician will verify that repairs meet the manufacturer's specifications and if all is correct the Emission Technician will unlock the analyzer.

NAC 445B.470 Test station: Display of licenses; availability of reference information. ([NRS 445B.210](#), [445B.770](#), [445B.785](#))

1. The license to operate a test station and all licenses issued to approved inspectors must be displayed in a conspicuous place under glass or other transparent material at a height of not less than 4 feet and not more than 6 feet within an area of the test station that is accessible to and frequented by customers.

2. Except as otherwise provided in subsection 3:

(a) A test station shall keep the operator's manual for its exhaust gas analyzer readily available to the approved inspector.

(b) A test station shall have readily available to the approved inspector a reference manual or equivalent information stating the emissions devices which are required by state and federal law to be installed on each type of motor vehicle that is inspected. The owner of the test station or his designee shall, upon the request of a representative of the

Department, demonstrate the availability of the reference manual or equivalent information by accessing the manual or information.

(c) An authorized station or class 2 fleet station shall have readily available to the class 2 approved inspector reference information in the form of printed or electronic media explaining the operation and maintenance of the emissions devices which are required by state and federal law to be installed on each type of motor vehicle. The owner of the test station or his designee shall, upon the request of a representative of the Department, demonstrate the availability of the reference information:

(1) If a telephone or facsimile transmission is not required to access the reference information, by accessing the reference information; and

(2) If the reference information is accessible only through the use of a telephone or facsimile transmission, by using the telephone or facsimile transmission to obtain and provide to the representative of the Department one copy of the reference information.

3. A fleet station is not required to maintain the specifications or instructions of the manufacturer for any motor vehicles other than those motor vehicles used and serviced by the fleet station.

NAC 445B.472 Test station: Records of inspections and repairs; inspection of place of business; audit of exhaust gas analyzers. ([NRS 445B.210](#), [445B.770](#), [445B.785](#), [445B.790](#))

1. Each test station shall maintain and have available for collection, records of all inspections and repairs, as may be applicable, for evaluation of the information at the request of the Department.

2. Except as otherwise provided in subsection 3, the principal portion of the established place of business of a test station must be open to inspection by any authorized agent of the Department during regular business hours as set forth in [NAC 445B.480](#).

3. The Department may grant an exception to the requirement set forth in subsection 2 for good cause shown upon a request submitted to the Department by a test station in writing or by electronic mail.

4. A representative of the Department will perform an audit of all exhaust gas analyzers located at a test station a minimum of once every calendar month.

5. A representative of the Department will perform an accuracy audit using specialty gas specifically designed for that purpose on all exhaust gas analyzers located at a test station a minimum of once every quarter in each calendar year.

Slide 16 Covert Audits

The Department conducts covert inspections of all Test stations and the performance of all approved inspectors.

The Department monitors the rates of failure of motor vehicles at the test station and by all approved inspectors for abnormal rates compared to the averages of

all test stations and all approved inspectors in initiating covert inspections beyond the normal annual requirement:

In addition, complaints received against approved inspectors and test stations, any Violations of Nevada Emission Rules and Regulations, or 40 C.F.R. Part 51 (the Federal Clean Air Act), that are noted during prior inspections or audits conducted by the Department, and any data on the state electronic data transmission system relating to a test station or approved inspector that the Department determines is questionable may trigger covert audits.

A motor vehicle's emission control system will be altered so that an approved inspector, using due care and following the prescribed testing procedures, will be able to readily, **visually**, identify the emission control system or component that has been tampered with, is missing, or does not appear functional, for use in a covert inspection.

If during a covert inspection a violation of the rules and regulations pertaining to the emission inspection procedures occurs, The Department will issue a preliminary written notice of the violation to the approved inspector who committed the violation, or, if they are no longer present, the preliminary written notice will be given to any other employee of the test station who is present and then a copy will be sent to the approved inspector who committed the violation by certified mail within 5 business days.

The approved inspector who committed the violation or, if they are not there, the person that we delivered the written notice to, will be allowed to inspect the motor vehicle used in the inspection before removing it from the test station.

NAC 445B.7015 Annual and additional inspections. ([NRS 445B.790](#))

1. The Department will conduct:
 - (a) Annual inspections of test stations; and
 - (b) Inspections of the performance of approved inspectors.
2. In addition to the annual inspections of test stations required pursuant to paragraph (a) of subsection 1, the Department may determine that additional inspections of test stations are necessary based on the following factors:
 - (a) Rates of failure of motor vehicles on exhaust emissions tests administered at a test station or by an approved inspector that the Department determines to be abnormal when

compared to the overall rates of failure of motor vehicles on exhaust emissions tests administered at all test stations and by all approved inspectors;

(b) Complaints received against test stations and approved inspectors;

(c) Violations of [NRS 445B.700](#) to [445B.845](#), inclusive, or 40 C.F.R. Part 51 discovered by the Department during prior inspections conducted pursuant to subsection 1 or prior inspections or audits conducted pursuant to [NAC 445B.472](#); and

(d) Any data on the state electronic data transmission system relating to a test station or approved inspector that the Department determines is questionable.

NAC 445B.7025 Alteration of emission control system of vehicle used to conduct inspection. ([NRS 445B.790](#)) For the purposes of an inspection conducted pursuant to [NAC 445B.7015](#), the emission control system of a motor vehicle that is used by the Department to conduct the inspection will be altered in such a manner that an approved inspector, using due care and following the testing procedures described in [NAC 445B.580](#), [445B.5805](#) and [445B.589](#), would readily identify, through only a visual inspection of the vehicle, that the emission control system of the vehicle has been tampered with or is missing or inoperable.

NAC 445B.7035 Preliminary written notice of violation; reinspection of vehicle. ([NRS 445B.790](#))

1. If the Department discovers noncompliance with any of the testing procedures set forth in [NAC 445B.580](#), [445B.5805](#) or [445B.589](#) during an inspection conducted pursuant to [NAC 445B.7015](#), the Department will issue a preliminary written notice of the violation, on a form prescribed by the Department, to the approved inspector who committed the violation. If the approved inspector who committed the violation is no longer present at the test station, the Department will:

(a) Give the preliminary written notice of the violation to another approved inspector or any other employee of the test station who is present; and

(b) Send a copy of the written preliminary notice to the approved inspector who committed the violation by certified mail not later than 5 business days after the violation occurred.

2. Before removing the motor vehicle used in the inspection conducted pursuant to [NAC 445B.7015](#) from the test station, the Department will allow the approved inspector who committed the violation or, in the absence of the approved inspector, the person to whom the preliminary written notice of the violation was given pursuant to paragraph (a) of subsection 1, to inspect the motor vehicle used in the inspection.

3. If the approved inspector who committed the violation is not the owner of the test station where the violation occurred, the Department will send a copy of the written preliminary notice to the owner by certified mail not later than 5 business days after the violation occurred.

Slide 17 Penalties for Inspectors

On Covert Audits

Administrative fines or other penalties may be imposed against an approved inspector by the Department for any violation of NAC 445B.580, 5805 or 589 during a covert audit, for violations occurring within a 2-year period according to the following schedule:

For a first offense the department will issue a cease and desist order, **and** require the approved inspector to complete an educational course conducted by the Department, not later than the date specified.

For a second offense the Department will impose a fine of \$250, **and** require the approved inspector to complete successfully an educational course established by the Department and conducted by a provider approved by the Department, not later than the date specified **and** suspend the license for **10** calendar days.

For a third offense the Department will impose a fine of \$500 **and** suspend the license of the approved inspector for **90** calendar days.

If there is a fourth offense the license will be permanently revoked.

NAC 445B.7045 Administrative fines and other penalties for certain violations.)

...

2. If the Department imposes administrative fines or other penalties against an approved inspector pursuant to [NRS 445B.835](#) for a violation of [NAC 445B.580](#), [445B.5805](#) or [445B.589](#), the Department will impose such fines or other penalties for violations occurring within the 2-year period immediately preceding the most recent offense according to the following schedule:

(a) For a first offense:

(1) Issue a cease and desist order; and

(2) Require the approved inspector to complete successfully an educational course, which is established and conducted by the Department, not later than the date specified in the notice of the violation.

(b) For a second offense:

(1) Impose a fine of \$250;

(2) Require the approved inspector to complete successfully an educational course, which is established by the Department and conducted by a provider approved by the Department, not later than the date specified in the notice of the violation; and

(3) Suspend the license of the approved inspector for 10 calendar days.

(c) For a third offense:

(1) Impose a fine of \$500; and

(2) Suspend the license of the approved inspector for 90 calendar days.

(d) For a fourth offense, permanently revoke the license of the approved inspector.

3. Any person who has been fined in accordance with the schedules set forth in this section shall make payment to the Department not later than the date specified in the notice of the violation, unless the person has requested a hearing pursuant to subsection 1 of [NRS 445B.835](#).

4. Upon the failure of a person to pay a fine or comply with any directive imposed pursuant to the provisions of this section, the Director may suspend, revoke or refuse to issue any license obtained pursuant to the provisions of [chapter 445B](#) of NRS.

...

6. An approved inspector whose license is revoked or suspended by the Department pursuant to this section shall not directly or indirectly engage in any activity pursuant to this chapter or [chapter 445B](#) of NRS that is related to emission control inspections of motor vehicles.

7. For the purposes of this section, the curriculum for an educational course established by the Department may include, without limitation:

(a) The pertinent laws and regulations related to the control of emissions of motor vehicles;

(b) Procedures for emission control inspections of motor vehicles;

(c) The responsibilities of owners of test stations; and

(d) A review of the penalties which may be imposed on the owner of a test station or an approved inspector for future violations of [NRS 445B.700](#) to [445B.845](#), inclusive, or any rule, regulation or order adopted or issued pursuant thereto.

Slide 18 Administrative fines

If a violation occurs at any time other than during a covert audit, the Department may impose administrative fines for violations occurring within a 2-year period, according to the following schedule:

For a first offense, the Department will impose a fine of not less than \$100 or more than \$500.

A cease and desist order issued by the Department is considered a first offense.

For a second offense, the Department will impose a fine of not less than \$500 or more than \$1,000.

For a third offense, the Department will impose a fine of not less than \$1,000 or more than \$1,500.

For a fourth or subsequent offense, the Department will impose a fine of not less than \$1,500 or more than \$2,500.

If a person fails to pay a fine or comply with any directive imposed pursuant to the provisions of this section, the Director may suspend, revoke or refuse to

issue any license obtained pursuant to the provisions of 445B of NRS, unless the person has requested a hearing as per 445B.835.

If your license has been suspended or revoked you shall not directly or indirectly engage in any activity related to the control of emissions or emission inspections, and you must wait one year before you may reapply for a license, there is no guarantee that one will be granted.

Additionally civil penalties may be pursued by the Department or by an individual customer.

NAC 445B.727 Administrative fines and other penalties.

1. Except as otherwise provided in subsections 2 and 3 and [NAC 445B.7045](#), if the Department imposes administrative fines pursuant to the provisions of [NRS 445B.835](#), it will impose such fines for violations occurring within the 2-year period immediately preceding the most recent offense according to the following schedule:

- (a) For a first offense, a fine of not less than \$100 or more than \$500.
- (b) For a second offense, a fine of not less than \$500 or more than \$1,000.
- (c) For a third offense, a fine of not less than \$1,000 or more than \$1,500.
- (d) For a fourth or subsequent offense, a fine of not less than \$1,500 or more than \$2,500.

↔ ¶ For the purposes of paragraphs (b), (c) and (d), a cease and desist order issued by the Department shall be deemed to be a first offense.

2. If the Department imposes administrative fines on an owner or operator of a heavy-duty motor vehicle powered by diesel for a violation of the standards of opacity established pursuant to [NRS 445B.780](#), it will impose such fines for violations occurring within the 1-year period immediately preceding the most recent offense according to the following schedule:

(a) For a first offense, a fine of \$800. The Department will not impose this fine if demonstration of correction is provided within 45 calendar days after the receipt of the citation.

(b) For a second or subsequent offense, a fine of \$1,500.

↔ ¶ For the purposes of paragraph (b), a cease and desist order issued by the Department shall be deemed to be a first offense.

3. The Department may impose a fine of not less than \$1,500 or more than \$2,500 for any violation of [NAC 445B.460](#) or subsection 4 of [NRS 445B.840](#).

4. Any person who has been fined pursuant to the provisions of [NRS 445B.835](#) shall make payment to the Department not later than the date specified in the notice of the violation, unless he has requested a hearing pursuant to subsection 1 of that section.

5. Upon the failure of a person to pay a fine imposed pursuant to the provisions of this section when it becomes due, the Director may suspend, revoke or refuse to issue any license obtained pursuant to the provisions of [chapter 445B](#) of NRS.

Slide 19 Owner Penalties

The owner of the test station may be held responsible for any act or omission of an approved inspector or any other employee employed at any test station owned by the owner which is committed while the inspector or other employee is acting within the scope of his employment, and which would constitute a violation of NRS 445B or NAC 445B.

Administrative fines for an owner

The Department will impose fines for violations not related to a covert audit, occurring within the 2-year period immediately preceding the most recent offense according to the following schedule:

For a first offense, the Department will impose a fine of not less than \$100 or more than \$500.

A cease and desist order issued by the Department is considered a first offense
For a second offense, the Department will impose a fine of not less than \$500 or more than \$1,000.

3. For a third offense, the Department will impose a fine of not less than \$1,000 or more than \$1,500.

4. For a fourth or subsequent offense, the Department will impose a fine of not less than \$1,500 or more than \$2,500.

For violations on a covert audit, the Department will impose such penalties for violations occurring within a 2-year period, according to the following schedule:

For a first offense, the Department will issue a written notice of violation.

For a second offense, the Department will require the owner of the test station or his authorized representative to complete an educational course, which is established and conducted by the Department, not later than the date specified in the notice of the violation.

For a third offense, the Department will impose a fine of \$1,000.

4. For a fourth offense, the Department will revoke the license of the owner to operate the test station.

An owner of a test station whose license is revoked by the Department pursuant to this section shall not directly or indirectly engage in any activity related to emission control inspections of motor vehicles.

Additionally civil penalties may be pursued by the Department or an individual customer.

NAC 445B.7045 Administrative fines and other penalties for certain violations.

1. If the Department imposes administrative fines or other penalties against an owner of a test station pursuant to [NRS 445B.835](#) for a violation of [NAC 445B.4985](#), the Department will impose such fines or other penalties for violations occurring within the 2-year period immediately preceding the most recent offense according to the following schedule:

(a) For a first offense, issue a cease and desist order.

(b) For a second offense, require the owner of the test station or his authorized representative to complete successfully an educational course, which is established and conducted by the Department, not later than the date specified in the notice of the violation.

(c) For a third offense, impose a fine of \$1,000.

(d) For a fourth offense, revoke the license of the owner to operate the test station.

...

3. Any person who has been fined in accordance with the schedules set forth in this section shall make payment to the Department not later than the date specified in the notice of the violation, unless the person has requested a hearing pursuant to subsection 1 of [NRS 445B.835](#).

4. Upon the failure of a person to pay a fine or comply with any directive imposed pursuant to the provisions of this section, the Director may suspend, revoke or refuse to issue any license obtained pursuant to the provisions of [chapter 445B](#) of NRS.

5. An owner of a test station whose license is revoked by the Department pursuant to this section:

(a) Shall not directly or indirectly engage in any activity pursuant to this chapter or [chapter 445B](#) of NRS that is related to emission control inspections of motor vehicles, if the violation:

(1) Was knowing or willful; or

(2) Involved fraud.

(b) May directly or indirectly engage in any activity pursuant to this chapter or [chapter 445B](#) of NRS that is related to emission control inspections of motor vehicles at a test station other than the test station where the violation occurred, if the violation:

(1) Was not knowing or willful; and

(2) Did not involve fraud.

...

7. For the purposes of this section, the curriculum for an educational course established by the Department may include, without limitation:

- (a) The pertinent laws and regulations related to the control of emissions of motor vehicles;
- (b) Procedures for emission control inspections of motor vehicles;
- (c) The responsibilities of owners of test stations; and
- (d) A review of the penalties which may be imposed on the owner of a test station or an approved inspector for future violations of [NRS 445B.700](#) to [445B.845](#), inclusive, or any rule, regulation or order adopted or issued pursuant thereto.

Slide 20 Fine Matrix

The Fine Matrix is in the appendix.

Slide 21 Program Areas

Maps are located in the Appendix.

All gasoline powered vehicles within the applicable year range are required to be inspected annually for renewal and on initial registration in Nevada, only if they are based in these two areas:

Washoe County, including the entire area below the 40th degree of north latitude, except for addresses that are serviced by these post offices; Crystal Bay, Nixon, Wadsworth, Empire, Incline Village, and Sutcliffe.

Clark County, including the entire hydrographic basin 212 including the five mile buffer zone, as well as the entire city limits of Boulder City. The only exempt area within Clark County is any address serviced by the Goodsprings Post Office.

NAC 445B.593 Evidence of compliance required for certain vehicles based in Clark County.

1. Except as otherwise provided in subsection 2, persons who are registering or reregistering a used motor vehicle in Clark County must provide evidence of compliance with [NAC 445B.400](#) to [445B.735](#), inclusive, for those vehicles which are based at an address:

- (a) Within the boundaries of Hydrographic Area 212, as established by the State Implementation Plan;
- (b) Within 5 miles of the boundaries of Hydrographic Area 212, as established by the State Implementation Plan; or
- (c) Within the city limits of Boulder City.

2. A person who is registering or reregistering a used motor vehicle in Clark County is not required to provide evidence of compliance with [NAC 445B.400](#) to [445B.735](#),

inclusive, for the vehicle if the vehicle is based at an address within the community of Goodsprings.

3. The Department will establish and maintain a list by zip code of the addresses in Clark County that are subject to the requirements of this section and the addresses in Clark County that are exempted from the requirements of this section.

4. As used in this section, "State Implementation Plan" means the plan adopted by the State of Nevada pursuant to 42 U.S.C. §§ 7410 and 7502.

NAC 445B.594 Evidence of compliance required for certain vehicles based in Washoe County.

1. Except as otherwise provided in subsection 2, persons who are registering or reregistering used motor vehicles in Washoe County must provide evidence of compliance with [NAC 445B.400](#) to [445B.735](#), inclusive, for those vehicles which are based at an address that is south of the 40th degree of north latitude.

2. A person who is registering or reregistering a used motor vehicle in Washoe County is not required to provide evidence of compliance with [NAC 445B.400](#) to [445B.735](#), inclusive, for the vehicle if the vehicle is based at an address:

(a) Within the community of:

- (1) Crystal Bay;
- (2) Empire;
- (3) Incline Village;
- (4) Nixon;
- (5) Sutcliffe; or
- (6) Wadsworth; or

(b) Which is serviced by a post office for any of the communities listed in paragraph (a).

3. The Department will establish and maintain a list by zip code of the addresses in Washoe County that are subject to the requirements of this section and the addresses in Washoe County that are exempted from the requirements of this section.

Slide 22 Private party sales, Dealer sales, Assembled Vehicles, Gray market vehicles and Engine swaps

On **Private party** sales the **buyer** is responsible for the emission inspection, not the seller. The **seller** is responsible to be sure that all required emission control equipment is present and appears functional.

On Dealer sales a passing VIR is required to be presented to the buyer at the presentation of the DRS, that is the Dealer Report of Sale, and the dealer is responsible to be sure that all required emission control equipment is present and appears functional, regardless of the vehicles age.

This is enforced by DMV.

An **Assembled Vehicle** or **ASVE** is tested by year of the engine. The owner must supply proof of year of the engine to the Department. If the year of the engine can not be determined it will be tested by the year on the registration or title.

Gray market vehicles are vehicles that were built to be sold in countries other than the United States of America, and are not built to specifications of the United States of America.

Engine swaps are vehicles that do not have the original type and/or year of engine.

All assembled vehicles, gray-market vehicles, and engine swaps must be verified by the local Emission Lab.

Slide 23 Exempt vehicles

All mopeds and motorcycles; apportioned vehicles; not based in a I/M program area of Nevada; Classic Vehicles or Classic Rods that are presently plated Classic Rod or Vehicle and have been driven less than 2500 miles in the year since last registration; transfer of ownership within 90 days of a current passing VIR, (Vehicle Inspection report); transfer of ownership between spouses; all vehicles that will have been registered for less than 24 months; all vehicles with a model year prior to 1968; any Hybrid vehicle until the sixth model year, they are exempt for the first five model years; and Alternate fueled vehicles, that is CNG, Propane, Hydrogen, Etc.

NAC 445B.592 Applicability of certain standards for emissions and other requirements.

The provisions of subsection 3 of [NAC 445B.576](#) and [NAC 445B.593](#) to [445B.596](#), inclusive, do not apply to any:

1. Motorcycle or moped.
2. Motor vehicle which is subject to prorated registration pursuant to [NRS 706.801](#) to [706.861](#), inclusive, and is not based in this State.
3. New motor vehicle until the third registration of the vehicle.
4. Motor vehicle permanently converted from gasoline to propane, compressed natural gas (CNG), methane or butane as a fuel.
5. Motor vehicle with a model year before 1968.

6. Heavy-duty motor vehicle which has a manufacturer's gross vehicle weight rating of more than 14,000 pounds and which is powered by a diesel engine.

Slide 24 Applicants Guide and Training Checklist

The Applicants Guide and Pre-Practical Training Checklist lists everything you must know and understand in order to pass the practical examination and become licensed.

It can be found in the Appendix.

You should take this with you to the analyzer and/or outside training classes.

Check off each item after you are trained on it, fully understand it, and are confident you can complete the task. If you do not understand the item, do not check it off. Ask your instructor for additional explanation and/or training.

When all the boxes are checked, you have completed your training. Then and only then, sign and date the checklist. This is for your signature only and attests to the fact you have been fully trained on each item and fully understand it.

Bring the signed checklist with you to the practical.

Slide 25 Analyzer

The Analyzer description is in the appendix.

Slide 26 Beginning an Inspection

Preparing to conduct an emission test

To determine if a test is required, you must ascertain that the inspection is for registration. The inspection must be for registration purposes only.

The vehicle must be registered or going to be registered in a program area of Clark or Washoe Counties and not in an exempt city. It must be a correct Zip Code, one that requires a test.

Determine if the vehicle was just purchased and was it a dealer sale. If so the dealer must supply the passing VIR. If it was a private party transaction, the inspection must be for the buyer.

The Inspector is required to be certain the vehicle is fully warmed up on 1995 and earlier vehicles and heavy duty vehicles.

It should not sit and cool down before the tailpipe test. This applies only on a tailpipe test, OBD testing does not require preconditioning.

If a vehicle is tested that didn't require a test, or was failed incorrectly, such as due to being cold, or was not inspected following the correct procedure, the customer is entitled to a complete refund for all labor fees and certificate fees that may have been charged.

If the vehicle requires an emission inspection and the customer requests an inspection the vehicle must be tested as received, no pre-testing is allowed.

NAC 445B.580 Inspection of vehicle: Procedure for certain vehicles with model year of 1995 or older and heavy-duty vehicles with model year of 1996 or newer

1. Except as otherwise provided in subsection 4, the provisions of this section apply to inspections of:

- (a) All motor vehicles with a model year of 1968 to 1995, inclusive; and
- (b) With regard to motor vehicles with a model year of 1996 or newer, all heavy-duty motor vehicles.

2. After the owner or operator of a motor vehicle subject to the provisions of this section requests an inspection, an approved inspector shall follow the sequence of prompts displayed by the exhaust gas analyzer when conducting the inspection. While the vehicle is at normal operating temperature, the inspector shall connect the exhaust gas analyzer to the vehicle following the sequence of instructions programmed into the analyzer. The probe of the analyzer must be placed in the exhaust pipe of the vehicle. With the engine speed increased to 2,500 revolutions per minute, a steady level of carbon monoxide and hydrocarbons must be recorded by the analyzer. The engine speed must be returned to idle and a steady level of carbon monoxide and hydrocarbons must be recorded. If the vehicle is equipped with dual exhaust pipes, a test must be completed on both exhaust pipes and the average level of carbon monoxide and hydrocarbons must be recorded when the engine speed is increased to 2,500 revolutions per minute and when the engine speed is returned to idle.

3. The inspector shall visually inspect:

- (a) The exhaust system to determine whether or not there is smoke when idling and at 2,500 revolutions per minute; and
- (b) The engine to determine whether or not there are blowby gases from the crankcase when idling and at 2,500 revolutions per minute.

4. The inspector shall:

(a) Visually inspect:

- (1) All motor vehicles subject to the provisions of this section to determine the presence of a properly installed gas cap; and

(2) Each motor vehicle with a model year of 1981 to 1995, inclusive, and, with regard to motor vehicles with a model year of 1996 or newer, each heavy-duty motor vehicle, to determine the presence of an exhaust gas recirculation system, catalytic converter, air injection system and fuel inlet restricter, and to determine whether that equipment appears to be operating in accordance with the specifications of the manufacturer of the vehicle; and

(b) Enter the results of the visual inspection into the analyzer.

5. The inspector shall complete each test and issue a vehicle inspection report indicating whether or not the vehicle passes the inspection.

6. The inspector shall issue a vehicle inspection report indicating that the vehicle did not pass the inspection if:

(a) The emissions from the vehicle exceed the maximum levels for carbon monoxide or hydrocarbons, or both, as prescribed in [NAC 445B.596](#);

(b) Smoke or blowby is visible; or

(c) The vehicle does not meet the requirements of [NAC 445B.579](#).

7. If a motor vehicle subject to the provisions of this section passes all portions of an inspection but has an improper gas cap or no gas cap, the owner or operator of the motor vehicle shall obtain a gas cap which is in accordance with the specifications of the manufacturer of the vehicle. The inspector shall inspect the new gas cap and certify its presence in a manner prescribed by the Department, and sign and date the failing vehicle inspection report beneath the gas cap tamper description. Such a vehicle inspection report may be used as evidence of compliance.

NAC 445B.5805 Inspection of vehicle: Procedure for light-duty vehicles with model year of 1996 or newer.

1. The provisions of this section apply to inspections of light-duty motor vehicles with a model year of 1996 or newer.

2. After the owner or operator of a motor vehicle subject to the provisions of this section requests an inspection, the inspector shall:

(a) Turn the ignition switch to the off position for at least 12 seconds.

(b) Locate the data-link connector for the vehicle and connect the test equipment.

(c) Visually inspect the operation of the malfunction illumination light while turning the ignition switch to the run position with the engine off.

(d) Start the vehicle and, with the engine running, establish communication with the certified on-board diagnostic system installed in the vehicle.

(e) Visually inspect the vehicle to determine whether the malfunction illumination light is commanded on.

(f) Review the emission readiness code status.

(g) Retrieve all data trouble codes that are present.

3. The inspector shall complete each test and issue a vehicle inspection report indicating whether or not the vehicle passes the inspection.

4. The inspector shall issue a vehicle inspection report indicating that the vehicle did not pass the inspection if:

(a) The vehicle has a malfunction illumination light that fails to illuminate during a visual inspection while the ignition switch is turned to the run position with the engine off;

- (b) The vehicle has its malfunction illumination light commanded on continuously;
- (c) The vehicle has a data-link connector that is missing, has been tampered with or is inoperable, including related electrical circuitry;
- (d) There is no serial data communication from the certified on-board diagnostic system installed in the vehicle;
- (e) The vehicle has a model year of 2001 or newer and has more than one unset readiness indicator;
- (f) The vehicle has a model year of 1996 to 2000, inclusive, and has more than two unset readiness indicators; or
- (g) Smoke is visible in the exhaust emissions from the vehicle with the engine speed at idle.

Slide 27 Main Menu

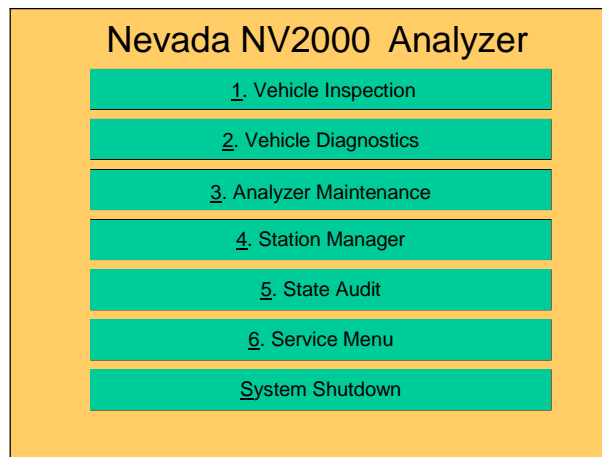

Some common screens you may encounter during emission testing.

This is an overview and is not intended to replace the outside training on testing and the analyzer which is critical to prepare you for the practical examination as well as conducting proper tests after you become licensed.

This is the main menu screen, it is the starting point for all emission testing.

Select: **1. Vehicle Inspection** to enter the Vehicle Inspection Menu.

Slide 28 Emission Inspection Menu

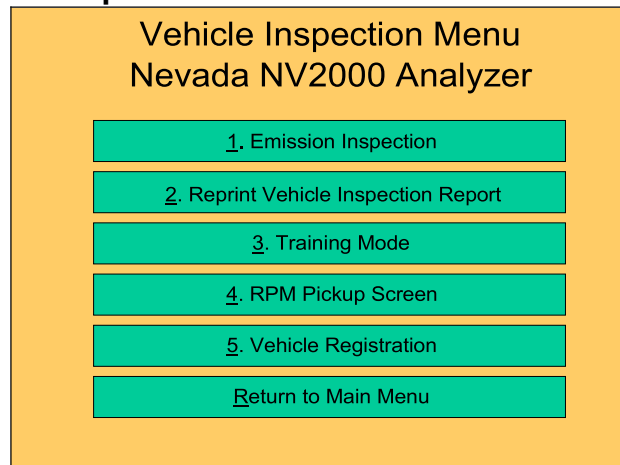

You are required to follow the emission analyzers screen prompts to the letter! This is the law.

An inspector must test the vehicle in the condition in which it was received. There are no exceptions.

No pre-testing! Pre-testing is revealing to the customer the outcome of the test prior to issuing the VIR or refusing the test for any other reason than safety or dilution.

You are required to perform the complete test, from start to finish.

To enter the emission inspection mode click on: 1. Emission Inspection.

Slide 29 User ID

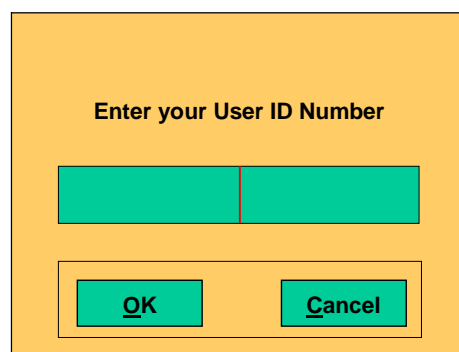

In the screen you enter your User ID Number. Remember that your User ID Number begins with MEI. It might have 0's (zeros), it will never have o's (oh's).

Slide 30 Password

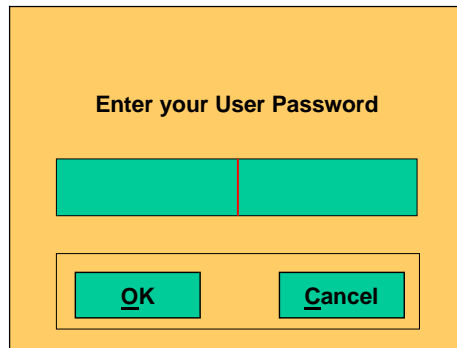

Enter your User Password

OK Cancel

Here you enter your User Password. Do not share your User Password with anyone.

NAC 445B.489 Grounds for denial, suspension or revocation of license.

The Department may deny the issuance of, suspend or revoke the license of an approved inspector if:

1. The approved inspector fails to establish by satisfactory evidence to the Department that he is employed by a test station with an appropriate rating.
2. The approved inspector has knowingly made any false statement or concealed any material fact on his application for a license.
3. The approved inspector knowingly submits false, inaccurate or misleading information on evidence of compliance or any other records submitted to the Department.
4. The approved inspector fails to report in writing to the Department every change in his place of employment or any termination of his employment within 10 days after the date of the change or termination.
5. The approved inspector does not follow the procedures for testing prescribed by the Department.
6. The approved inspector allows evidence of compliance to be completed or issued by a person who is not an approved inspector.
7. The approved inspector allows another person to perform emissions tests by using the identification number assigned to the approved inspector.
8. The approved inspector submits to the Department falsified credentials or certifications of training.
9. The approved inspector makes an inaccurate determination regarding a classification of a motor vehicle.
10. The approved inspector fails to comply with any provision of [NAC 445B.400](#) to [445B.735](#), inclusive.
11. The Department determines that an applicant or approved inspector is not lawfully entitled to a license.
12. The approved inspector is convicted for violating the provisions of [chapter 598](#) of NRS relating to deceptive trade practices.
13. The approved inspector is unable to demonstrate proficiency in the verbal and written expression of the English language.

NAC 445B.4983 Issuance of access code to approved inspector; use of access code and identification number.

1. In addition to the identification number assigned to each approved inspector, the Department will issue to each approved inspector a unique and confidential access code. The access code will enable the approved inspector to activate, access and input data into the exhaust gas analyzer located at the test station where he is employed.

2. An approved inspector, including, without limitation, the operator of a test station, shall not willfully or negligently allow any person to use his identification number or access code to:

- (a) Activate, access or input data into the exhaust gas analyzer; or
- (b) Issue a certificate of compliance.

If you input your password incorrectly three times, the VID will lock you out. To get your access restored, you are required to appear at the local emission lab in person, with your photo ID, to restore your access.

If you forget your password, you are required to appear at the emission lab in person, with your photo ID, to set a new password.

For security reasons these are not done over the phone, for your safety as well as protecting the security of the emission program.

Slide 31 VIN Entry

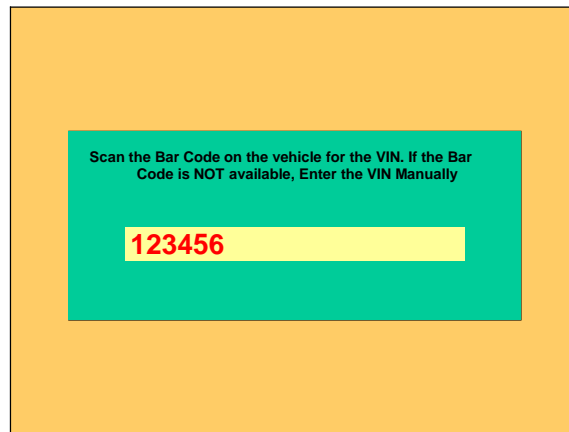

In this screen you may either scan the Vehicle's Identification Number (VIN) or enter it manually. If the VIN is entered manually it must be entered twice to verify and confirm the entry. If you use the scanner you must check your entry for errors.

The usual VIN location is the lower driver's side of the dash on a VIN plate. If the VIN is illegible or cannot be found, refer the customer to the local DMV VIN Inspectors, not the Emission Lab.

Remember any VIN error or any inspection information or data entry error will create an invalid VIR and a customer with an invalid VIR cannot renew his or her registration.

Any inspection information or data entry error on the VIR will require that the inspector retest the vehicle at no charge to the customer or return all fees.

DMV can not sign off an invalid VIR.

Slide 32 VIN Entry

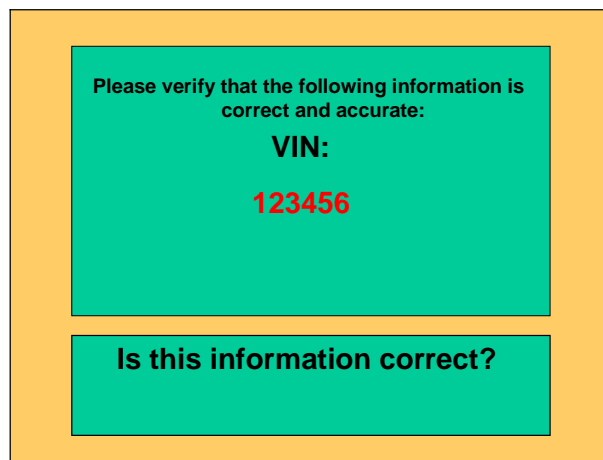

Please verify that the following information is correct and accurate:

VIN:

123456

Is this information correct?

This screen is your last chance to make changes in your VIN entry.

Verify your entry. Recheck the VIN at the vehicle. If it is not correct select NO and re-enter it correctly. If it is correct select YES and continue.

There are no o's or i's for that matter, in any VIN!

Note that on motorhomes you must use the VIN, not the chassis identification number. Check this against the registration documents. If there is a discrepancy contact the local Emission Lab.

Some barcodes on some vehicles are incorrectly coded by the manufacturer.

These must be input manually using the keyboard.

The accuracy of the input information is the inspector's responsibility.

In the event that a screen comes up, after contacting the VID, that indicates “W1501 multiple vehicles for given VIN”, you should verify your entry and then contact the Emission lab before proceeding so that the problem may be corrected for the future.

You should then continue with the test and inform the customer that they may not be able to renew the registration on line, at a kiosk, or over the phone until the problem is corrected. If the registration must be completed the same day, they may need to go in person to the local DMV.

Slide 33 State Messages

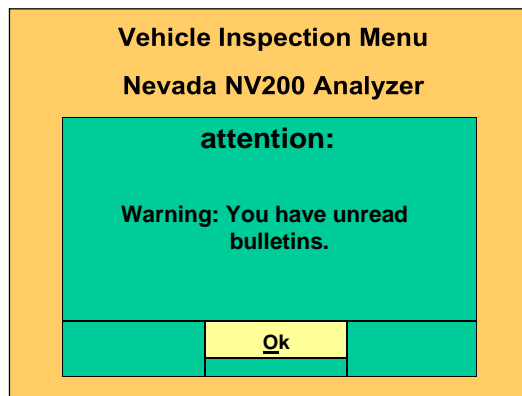

The State message screen alerts the inspector that a State Message or Urgent State Message is waiting for him on the DMV website. The inspector should select #7 inside the Manager Menu and log in using his MEI number and password. The inspector then needs to click on the magnifying glass to view the message. The inspector can print the message by clicking on the ‘print’ button at the bottom of the page.

The blue rules and regulations binder located at each shop is a very good place to store these.

This is one main means that the State has to get information out to the inspectors in the field.

You may continue to get a message notification until you log in and check them.

Slide 34 License Plate Type Entry

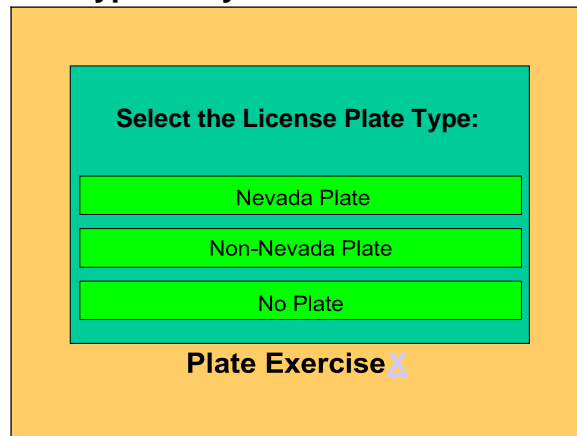

Select the License Plate Type:

Nevada Plate

Non-Nevada Plate

No Plate

Plate Exercise 

This is where you enter the license plate Type.

All license plates that say NEVADA on top are NEVADA license plates.

Any other State, Country or Territory license plate found on the vehicle is a Non-Nevada license plate. You must enter the state or foreign country that the license plate depicts.

Only license plates that say US GOVERNMENT on top are GOVERNMENT license plates.

If the vehicle has no license plates, click on the “No Plate” box.

Slide 35 No Plate Entry



Select the No-Plate reason:

Dealer Sale

Operating Permit

Out of State vehicle

Other

If you enter “No-Plate,” this screen will appear and you must then enter the reason the vehicle has no license plate.

Slide 36 License Number Entry

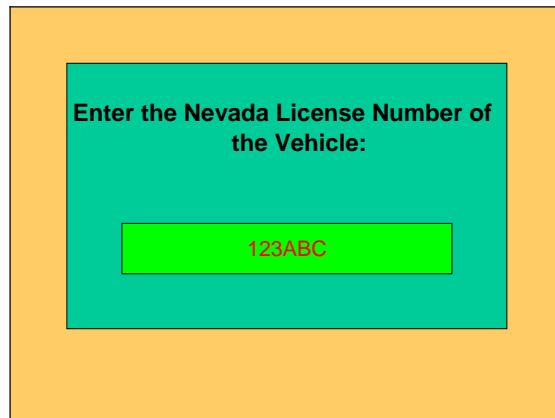

Enter the Nevada License Number of the Vehicle:

123ABC

Enter the license plate exactly as you see it. Run all numbers and letters together. Do not enter any spaces, dots, stars, or any other symbols.

Slide 37 License Entry Verification

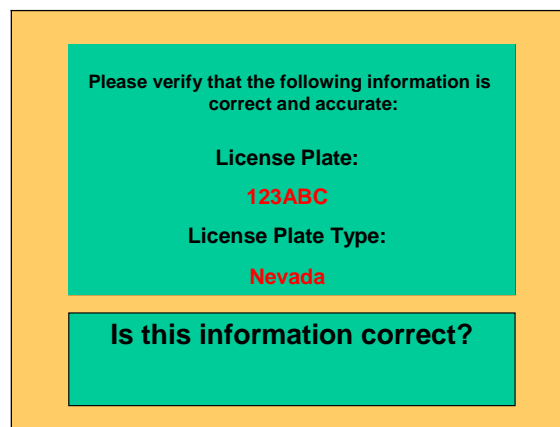

Please verify that the following information is correct and accurate:

License Plate:
123ABC

License Plate Type:
Nevada

Is this information correct?

This is the last chance to verify that the correct license plate number and type were entered.

If you have made an error click on **NO** and re-enter the correct information.

If everything is correct click on **YES** and continue with the test.

Remember any incorrect entry creates a invalid VIR and the test will have to be done over again at no charge to the customer.

Slide 38 County and Zip Entry

The screenshot shows a registration form with a yellow border. At the top, it says "Select The County Where The Vehicle Is Based". Below this is a green box containing three options: "Clark", "Washoe", and "Other". Underneath the green box, the text "Zip Code" is displayed, followed by the number "89104" in red. At the bottom of the form, there is a green box with the question "Is this information correct?".

Enter the County and ZIP Code the vehicle will be registered to. Only Clark and Washoe Counties require emission testing.

Enter '**Other**' if:

the vehicle has out of state plates and the customer has no local legal address; the customer has requested a test for a vehicle that is in an exempt area;

the vehicle is not based in Clark or Washoe Counties.

If a vehicle is tested that didn't require a test, or was failed incorrectly such as due to being cold, or was not inspected following the correct procedure, the customer is entitled to a complete refund for all labor fees and certificate fees that may have been charged.

NAC 445B.586 Evidence of compliance: Return of fee.

If evidence of compliance is not required for registration by [NAC 445B.592](#) to [445B.595](#), inclusive, or an inspection is performed by an inspector who the Department determines did not follow the correct procedures for inspection or is performed fraudulently, the authorized station or authorized inspection station where the inspection was performed shall remit to the bearer, upon demand, the amount of the fee for the inspection and the vehicle inspection report number.

Slide 39 Motorhome Entry

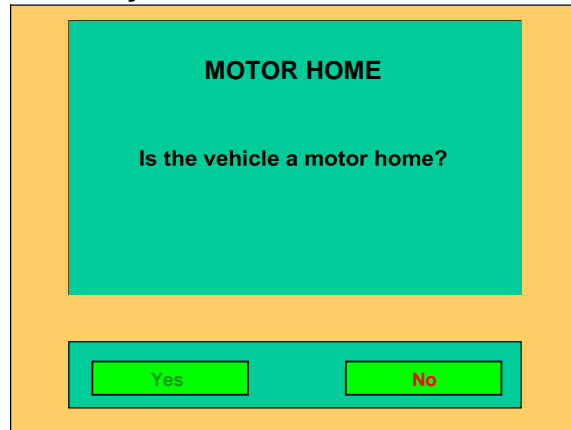

The screenshot shows a software interface with a yellow border. At the top, the text "MOTOR HOME" is centered in black. Below it, the question "Is the vehicle a motor home?" is centered in black. At the bottom, there are two green buttons with black text: "Yes" on the left and "No" on the right.

On this screen, you determine whether the vehicle is a motorhome. Motorhomes are automatically tested as heavy duty. Any size motorhome qualifies as a motorhome. The registration form or VIN Inspectors can be helpful since when a VIN Inspection is made, the DMV VIN Inspectors make the determination as to whether the vehicle is a Motor Home or a Van Conversion.

Slide 40 GVWR Entry

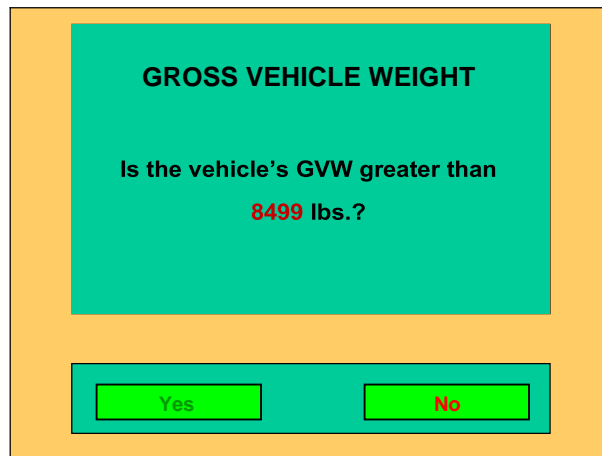

The screenshot shows a software interface with a yellow border. At the top, the text "GROSS VEHICLE WEIGHT" is centered in black. Below it, the question "Is the vehicle's GVW greater than 8499 lbs.?" is centered in black, with "8499 lbs.?" in red. At the bottom, there are two green buttons with black text: "Yes" on the left and "No" on the right.

You must determine if the GVW (Gross Vehicle Weight) is higher than 8499 pounds. Virtually all passenger cars are rated under 8500 pounds, as well as most SUVs. You will need to obtain the GVWR from the plate on the doorjamb and select yes or no accordingly.

You must accurately make this determination.

Contact the Emission Lab for guidance if needed.

This sets the standards and mode of testing.

Slide 41 Odometer Entry

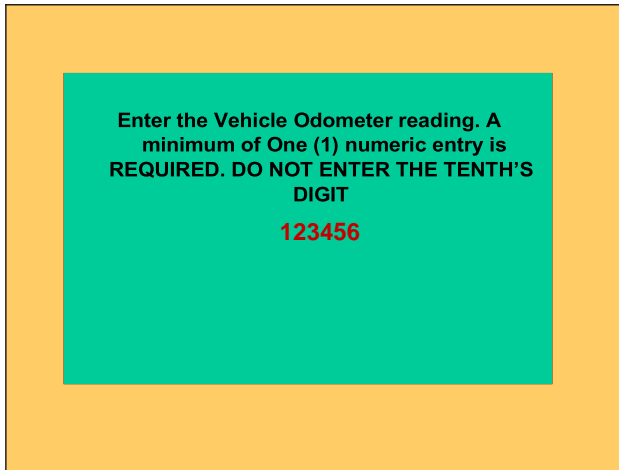

You must enter the odometer reading exactly as you see it.

Do not enter tenths or spaces. Do not enter O's (oh's), only 0's (zeros).

If the odometer is blank enter 1.

At this point, if the vehicle is a 1968-1995 light duty & 1968 to current heavy duty gasoline powered vehicles, you will now enter the two speed idle test or tail pipe test.

If the vehicle is a light duty 1996 to current you will now enter the OBD-II testing mode.

Slide 42 Communications screen

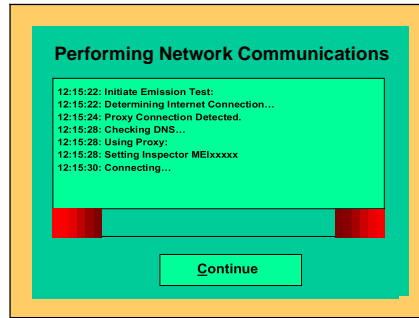

After you input the vehicles mileage the analyzer will begin communicating with the Vehicle Information Database (VID).

Do not move the analyzer while the disk is in operation, this may cause analyzer damage.

The analyzer will advise you when the communication session has been completed.

Slide 43 Warning: Passing Test on File

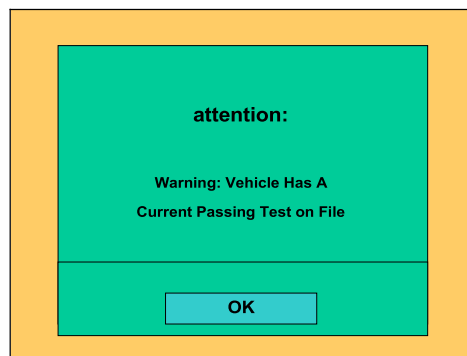

If this screen appears “**attention: Warning: Vehicle Has A Current Passing Test on File**” this means that this vehicle has a passing test recorded within the last 90 days.

If this happens ask questions to determine if the customer is aware that the vehicle does not require a test at this time.

Then explain to the customer that a test is not required.

If they require a copy of the VIR, the DMV emission lab personnel can re-print a VIR for the customer. There is no charge for that service.

All VIRs are valid for 90 days.

Slide 44 Vehicle Data Screen

The screenshot shows a 'Vehicle Data Screen' with the following fields and values:

Model Year	Vehicle Type	GVWR	Vehicle Make
2005	NOT APPLICABLE	N/A	Chevrolet

Number of Cylinders	Fuel Type	Ignition	Dual Exhaust
05	Gasoline/Electric	Conventional	YES
07	Gasoline - Conventi	Distributorless	
08	Flexible Fuel	Quad 4/Wireless	NO
	Gasoline		

The Vehicle Data Screen will most likely be “pre-populated” by the VID making all, or some, of these entries unnecessary.

If the VID has no record of the vehicle it cannot populate these fields.

In this case you must complete the entries to continue.

If necessary, you must correctly enter the model **year** of the vehicle, this can be determined by reading the under hood label or by matching the tenth digit of the vehicle identification number with a model year chart, the tenth-digit model year method does not apply to some 1980 and older vehicles.

And correctly enter the vehicle **make**, the **number of cylinders**, the **fuel type** and the **ignition type**, (Conventional, Distributorless or Quad four/wireless).

Slide 45 Exhaust Type Entry

The screenshot shows a software interface for entering vehicle information. It includes fields for Model Year (2005), Vehicle Type (NOT APPLICABLE), GVWR (N/A), and Vehicle Make (Chevrolet). Below these are fields for Number of Cylinders (05), Fuel Type (Gasoline - Conventi), Ignition (Conventional Distributorless), and Dual Exhaust (YES). At the bottom, there are buttons for 'Is This Information Correct?' with 'YES' and 'NO' options.

Model Year	Vehicle Type	GVWR	Vehicle Make
2005	NOT APPLICABLE	N/A	Chevrolet
Number of Cylinders	Fuel Type	Ignition	Dual Exhaust
05	Gasoline - Conventi	Conventional Distributorless	YES
07	Flexible Fuel	Quad 4/Wireless	NO
08	Gasoline		
Is This Information Correct?			
YES		NO	

Correctly enter exhaust type, **single** or **dual** exhaust.

If in doubt, test the vehicle as dual exhaust.

NAC 445B.580 Inspection of vehicle: Procedure for certain vehicles with model year of 1995 or older and heavy-duty vehicles with model year of 1996 or newer.

...

2. After the owner or operator of a motor vehicle subject to the provisions of this section requests an inspection, an approved inspector shall follow the sequence of prompts displayed by the exhaust gas analyzer when conducting the inspection. While the vehicle is at normal operating temperature, the inspector shall connect the exhaust gas analyzer to the vehicle following the sequence of instructions programmed into the analyzer. The probe of the analyzer must be placed in the exhaust pipe of the vehicle. With the engine speed increased to 2,500 revolutions per minute, a steady level of carbon monoxide and hydrocarbons must be recorded by the analyzer. The engine speed must be returned to idle and a steady level of carbon monoxide and hydrocarbons must be recorded. If the vehicle is equipped with dual exhaust pipes, a test must be completed on both exhaust pipes and the average level of carbon monoxide and hydrocarbons must be recorded when the engine speed is increased to 2,500 revolutions per minute and when the engine speed is returned to idle.

Slide 46 Dual Exhaust Diagram

The diagram is in the Appendix

Slide 47 Certification Label Entry

Enter Label Inspection Findings:

- 1. 50/49 State Certification
- 2. Label Missing
- 3. Mexico Certification
- 4. Canada
- 5. Other

This screen is asking for the certification status of the vehicle.

That means where it was certified to be sold.

If the label says it “meets Federal and California standards” it is a 50/49 state vehicle.

If it says “Meets California standards” it is a California vehicle and you would select 1. 50/49 State Certification.

If it is all in Spanish or French, it is probably certified for sale in some other country, not the United States, If the vehicle has a 17 digit VIN, call the Emission Lab to verify it meets United States standards.

Label missing means there is no label.

Other means it is certified for sale in some other country, not the United States, Canada, or Mexico.

If you run into a label that is entirely in a language other than English, the vehicle may be gray or black market and you should contact the Emission Lab for guidance.

Slide 48 Certification Label

The Under hood Emission label provides information in four areas using diagrams, codes, acronyms, and written information.

Area 1 is Engine Family Code and has twelve alpha/numeric characters. The family code has gone through three periods of distinct formatting. They are 1981-1993, 1994-1997, and 1998-present.

Area 2 is The Certification Statement and will indicate the model year of the vehicle.

It will also indicate where this engine is certified to operate. It either conforms to EPA (Federal) and/or California specifications, (49 state or California)

If the label appears altered in any way check model year against VIN and any reference book that you have, if you are still not sure, send it to the Emission Lab

Area 3 is the Catalyst Statement. Here is where the manufacturer is required by the federal government to indicate whether the vehicle has a catalyst or is non-catalyst. Some manufacturers will also list additional emission devices in this section.

Area 4 is the vacuum hose routing diagram which will show any emission devices that are vacuum operated.

Canadian Vehicles & Gray Market Vehicles

A foreign or gray market vehicle is a vehicle that is manufactured for sale in a country other than the United States. It may not meet US safety or emission standards and must be approved by US Customs and the Environmental Protection Agency before being allowed to enter the country.

These must be sent to the Emission Lab for verification.

Slide 49 Label Exercise

Slide 50 Emissions Exception Vehicle Form

An example of an Emissions Exception Vehicle report is in the Appendix. When a customer requests an emission test and presents you with this form, you must inspect the vehicle using the information found on this form, regardless of the emission label or an application guide.

You may see this form with ASVE, engine swaps, supplement engine labels, salvaged vehicles, gray market vehicle, Etc.

This information should already be input into the VID and will populate the appropriate fields during the inspection.

If you have any questions on testing one of these vehicles, contact your local State of Nevada Emission Lab.

Slide 51 First AIR Entry

On tailpipe testing, 1968 through 1995 light duty and through current year heavy duty it is the Inspectors responsibility to determine if the vehicle was required to be equipped with secondary air injection, not whether it actually has one installed now.

This sets the dilution standards for the analyzer.

If Air injection is required, but the input is that it does not have Air Injection, it may actually cause a rejection for dilution since, as the name implies, extra air is being injected into the exhaust which is diluting it.

If the vehicle does not require Air injection, but you input that it has Air injection, the standards may be affected and result in an invalid VIR.

In either case the result is an invalid VIR and a possible violation.

At the very least you may be required to retest the vehicle at no charge or return all fees to the customer.

Also remember that this entry must match the entry for Air injection tampering. If you say it has Air injection here and later input Air injection as N/A, or if you input that it does not have AIR and then pass or fail the Air Injection, these entries conflict and may result in a covert audit.

Slide 52 Quiz, in the Presentation only

Slide 53 Air Injection Equipped Entry

The screenshot shows a data entry interface with a yellow border. It contains two main sections. The top section has a blue background and contains the following text: "Enter the Vehicle Odometer reading. A minimum of One (1) numeric entry is REQUIRED. DO NOT ENTER THE TENTH'S DIGIT". Below this text is a red input field containing the number "123456". Underneath the input field is the question "Is the vehicle supposed to be equipped with an Air Injection System? (Y/N)". To the right of this question is a red input field containing the letter "Y". The bottom section of the form has a blue background and contains the question "Is this information correct?".

If the vehicle is a 1995 or older light duty or a 1996 or newer heavy duty, you are prompted here for an air injection entry.

If the vehicle is equipped from the factory with an air injection system, enter “**Y**” for yes. If the vehicle has a tampered air injection system you will still enter “**Y**” if air injection was originally installed by the factory.

If the vehicle was not equipped with air injection from the factory you will enter “**N**” for no. This indicates that the vehicle did not require air injection.

Confirm that the entry is correct.

If all is correct, click **Yes**.

If something is incorrect, click **No** and re-enter.

Slide 54 Tailpipe Test Start Screen

You Must Follow the Screen Prompts.

The vehicle must be tested as received.

On Tailpipe testing, that is on 1968-1995 light duty and 1968 to current year heavy duty gasoline powered vehicles you must Properly Chock the Wheels and Turn off all accessories.

The State of Nevada recommends that you **do not use throttle prop rods**, due to safety.

It is recommended that you sit in the vehicle and operate the throttle from there.

If you are behind the wheel you can apply the brakes and stop the vehicle, but if you are outside the vehicle there is very little you can do.

Wheel chocks alone will not stop a vehicle at 2500 RPM, and may not stop one at idle.

Verify that the engine is at normal operating temperature.

Slide 55 Known Problem Vehicles

There are lists of known problem vehicles and known testability issues. They are not intended to be complete listings of problem vehicles, simply a list of those that we are aware of.

They are intended as an aid to you in performing inspections.

These can be found at these websites, California BAR, Weber State, Colorado State, and probably others.

California BAR: <http://www.bar.ca.gov>

Weber State University: <http://www.obdclearinghouse.com>

Colorado State University: <http://ncvecs.colostate.edu/ncvecs1.html>

Slide 56 Insert Probe Screen

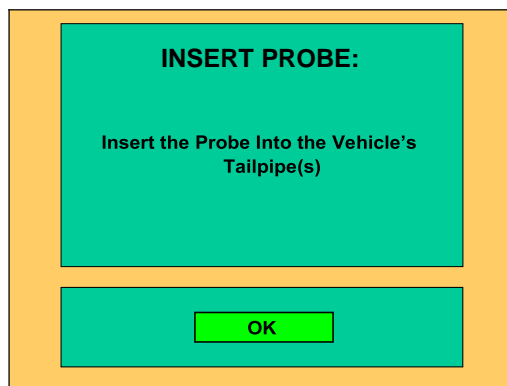

Fully insert the probe in the tailpipe making sure it will not fall out during the test. Install a needle probe if necessary, such as if there is a spark arrestor screen blocking the end of the tailpipe.

A vehicle can be tested with a damaged exhaust system as long as the probe will not fall out, and no dilution problem is indicated and no safety problem exists.

Slide 57 Tach Screen

The screenshot shows a software interface for tachometer verification. At the top left, two red boxes indicate 'IDLE (350 – 1250) NOT Verified' and 'HIGH (2200 – 2800) NOT Verified'. Below these is a 'Number of Cylinders' section with radio buttons for 2, 3, 4, 5 (selected), 6, 8, 10, 12, 16, and a 'Rotary' checkbox. To the right, an 'Indicate Cycle' section has radio buttons for Four (selected), Two, D.I.S., Quad, and Coil Over Plug. The 'Select RPM Pick-up Device' section has radio buttons for Contact (selected), Direct, Non-Contact, and OBD II. A digital display shows '785'. A red box on the right says 'RPM Reading Is not Stable'. At the bottom right is a 'Continue' button. Text on the right side reads: 'Verify that RPM remains stable at idle and high speed prior to exiting the pickup screen and beginning the emission test'. Below the device selection, it says: 'Non-Contact Requires Four cycle Selection. Rotary Engines require D.I.S. selection. Quad Requires Direct or Non-Contact Pick-up.'

In this screen you must choose the type of tachometer pick-up device being used and then verify low rpm tachometer signal and verify high rpm tachometer signal. When using the non-contact tachometer pick-up you must click on the four cycle setting.

If the vehicle is a Rotary and you are having trouble getting a viable signal, the VID may have reverted to 4 or 6 cylinder. Use the 2 cycle setting and the correct coil, (one coil may not fire at idle) and it should return proper RPM readings.

When using the OBDII pick-up be sure to click on the OBDII setting and follow the screen prompts.

Be aware that when using the contact setting you may need to change the cycle setting to bring the rpm into range.

For additional help you may call the Emission Lab in your area.

Check the Tach Notes for help if needed. These are in the Appendix.

Slide 58 High Speed mode

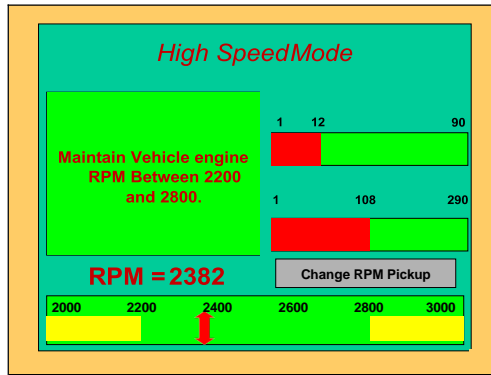

During the high speed mode you must maintain engine speed between 2200 and 2800 rpm.

Signal drop outs may cause a test rejection.

During this portion of the test be sure to check for visible smoke.

Check for smoke coming from the tailpipe and blowby from the crankcase.

Only smoke coming from the tailpipe or the crankcase will cause a failure.

Smoke from an oil leak does not count as a failure.

Slide 59 Dilution Screen

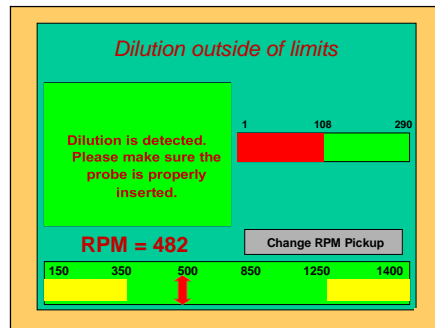

This dilution warning indicates that the analyzer is not getting a sufficient exhaust sample to test the exhaust.

This can be caused by a leak in the exhaust system of the vehicle, a damaged test hose or probe, a damaged filter bowl or gasket, a probe or probes that fell out of the exhaust pipe, even an improper fuel mixture can cause dilution.

After rejecting for dilution the analyzer will advise you to remove the sample hose and wait for the timer to count down.

If the dilution problem is present at the beginning of the test and the problem cannot be repaired the analyzer will reject the vehicle from testing. The problem must be corrected and the vehicle retested.

Remember an incomplete test due to idle speed or dilution is not a failure, it is a rejection.

The vehicle may need to be repaired and retested or the analyzer may need to be repaired.

When dilution is detected after the test has begun the analyzer will prompt you to check that the probe is inserted properly.

If the probe is inserted correctly the analyzer will halt the test until the problem is repaired.

If the problem cannot be repaired, the test can only be stopped by aborting the test.

This is the only reason you can abort unless a safety issue is involved.

Slide 60 Idle Speed Mode

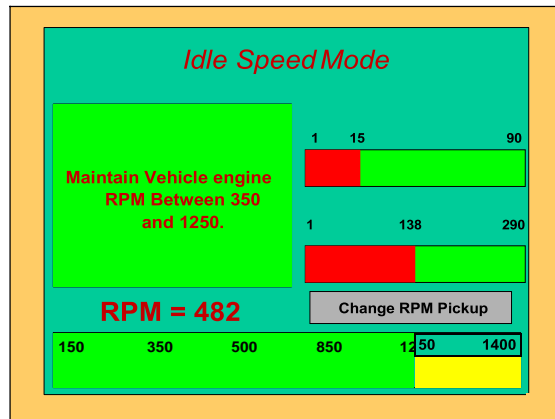

Make sure the vehicle is idling between 350 rpm & 1250 rpm.

Be sure the tachometer signal is stable.

During this portion of the test be sure to check for visible smoke.

Check for smoke coming from the tailpipe and blowby from the crankcase.

Only smoke coming from the tailpipe or the crankcase will cause a failure.

Smoke from an oil leak does not count as a failure.

Slide 61 Test Complete

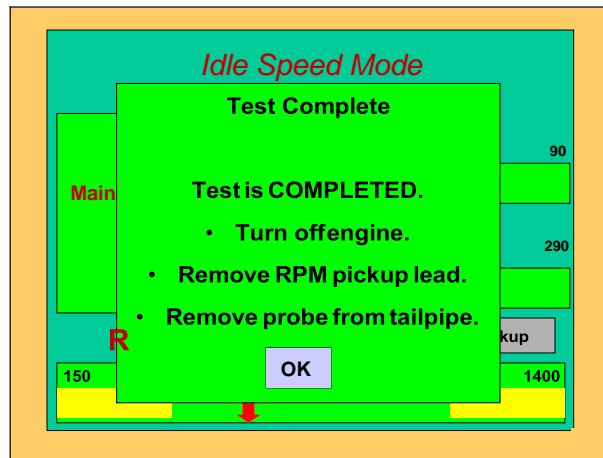

This screen indicates the test is now complete.

Follow the screen prompts carefully.

Turn off the engine. Remove test probe. Disconnect tachometer pick-up.

Close the contact pick-up to help prevent damage. A broken magnet may cause an erratic tachometer signal.

Remove the wheel chocks.

Slide 62 Smoke, Tailpipe Test

When performing a tailpipe test, you are required to observe the vehicle for smoke, both at Idle & 2500 RPM from the crankcase and the tailpipe.

Smoke coming from anywhere else does not apply.

If you observe any smoke at 2500 RPM or idle from the crankcase or the tailpipe, you must enter that on the analyzer at the prompt and it will cause a fail.

Remember this is on the **Tailpipe test only**, the **OBDII** test only requires a check for visible smoke at idle, and only at the tailpipe, not the crankcase.

Slides 63, 64 and 65 Are in the presentation only

Slide 66 Visible Smoke and Tampering

VISIBLE SMOKE and TAMPERING		
Is Visible Smoke Being Emitted from the Vehicle?	<input type="button" value="YES"/>	<input type="button" value="NO"/>
1. Air Injection System	<input type="button" value="P"/>	Source <input type="text"/>
2. EGR System	<input type="button" value="N"/>	Source <input type="text" value="4"/>
3. Catalyst	<input type="button" value="N"/>	Source <input type="text" value="2"/>
4. Fillpipe Restrictor	<input type="button" value="N"/>	Source <input type="text" value="3"/>
5. Fuel Cap	<input type="button" value="P"/>	Source <input type="text"/>
Please select one of the following codes: P for Pass; F for Fail; or N for Not applicable		

If the vehicle is smoking select “Yes”. A “Yes” selection will cause an overall test failure. If the vehicle is not smoking click “No”.

Next enter pass, fail or N/A (not Applicable) for each tamper device listed.

If you enter N/A you must enter the source of your information.

- 1 – Determination by Inspector
- 2 – Manufacturers Emission Label
- 3 – Emission Application Manual
- 4 – Other (such as electronic media)

Note: You do not have to enter a source if you enter Pass or Fail for a device.

Be advised that if you choose #1 “Determination by Inspector” and you are wrong you have no back-up for that decision.

You may be fined or have your license revoked, so it may be a good idea to take the time to find the information in #2, 3, or 4 so that you are covered.

Slide 67 Air Injection Tamper Entry

You are now required to determine if the vehicle is required to have an Air Injection system and **does it appear functional?**

You are required to use whatever information sources are necessary to determine the requirement and configuration for the vehicles secondary air

injection system, that is what type of system is required, pump or pulse and what additional components are connected to the system.

You are certifying that the **entire** the system **appears functional** and it cannot appear functional if **any component** that is supposed to be there is missing, damaged or disconnected.

Slide 68 Tampering Defined

Tampering means that all components that are inspected in our program, that were required to be installed on that particular vehicle configuration, make, model, year, must be present and appear to be functional. If any component does not appear functional it is considered tampered.

The Nevada emission test does not require you to visually inspect all emission systems.

On 1968 through 1980 vehicles the only equipment we visually inspect for is fuel caps.

On 1981 through 1996 light duty vehicles & 1981 to current heavy duty vehicles in addition to the fuel caps we inspect visually for: fuel inlet restrictors, secondary air injection systems, EGR systems, and catalytic converters.

On 1996 to current light duty vehicles we only visually inspect for the operational capability of the MIL, the presence and tampering of the DLC, and smoke from the tailpipe only. The vehicles own computer does the rest!

NAC 445B.452 “Tampering” defined.

“Tampering” means rendering inoperative or intentional misadjustment of any motor vehicle device or element of design intended to control exhaust emissions.

Slide 69 Application Guides

Application Guides and repair manuals are available in various media: Paper bound books; CD rom disks; Online services; and Fax services

Some sources are:

ARI/EETN 610-992-9838 www.auto-talk.com for Quick Reference Laminated Card and OBD Testing Manual

Weber State University Center for Automotive Science & Technology (free DLC guide) <http://www.obdclearinghouse.com> or <http://www.autocenter.weber.edu/OBD.htm>

Colorado State University (Free DLC Guide) <http://www.obdiicsu.com>
Motor Reference Guide or Alldata

1-800-332-1306 or 702-254-8561

Alldata 1-800-697-2533

Mitchell On Demand 1-800-933-2039

Snap-On Shop Key Contact Your Local Dealer

Slide 70 Quiz, in Presentation only

Slide 71 In Presentation only.

Slide 72 EGR Tamper Entry

You are now required to determine if the vehicle is required to have an EGR system and **does it appear functional?**

You are required to use whatever information sources are necessary to determine the type and configuration for the vehicle's EGR system. What type of system, what type of valve, and what additional components should be connected in the system are all items that you must determine. If any part of the system is missing, disconnected, mis-connected or otherwise tampered, there is no way the system can appear functional.

Slide 73 In Presentation only

Slide 74 Catalytic Converter(s) Tamper

For the Catalytic tamper inspection, you need to determine how many and what type are required. Then you need to make sure that they are installed and appear functional.

You are required to use whatever information source is required to be able to confirm that the correct catalysts are installed and appear functional. Are the A.I.R. tubes connected if required.

It cannot appear functional if any component that is supposed to be there is missing, damaged or disconnected.

Slide 75 Catalyst Identification



The exhaust must flow through the catalytic converter, so it will be in the exhaust system. Most are under the car, in front of the muffler. A few are under the hood, just below the exhaust manifold. Most, but not all, have heat shields.

Slide 76 Fuel Inlet Restrictor and Gas Cap

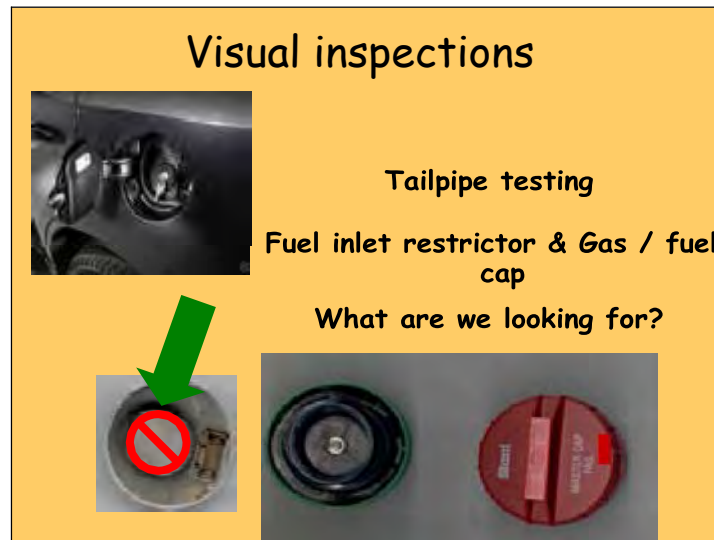

The Fuel inlet restrictor, also known as fillpipe restrictor, is there to “restrict fueling” to unleaded fuel. Leaded and diesel fuel nozzles are too big to fit through the restrictor.

Here you must determine that the restrictor has not been punched out or otherwise disabled. You need to look for it and pass or fail it accordingly, it is part of the inspection and you can be penalized if you do not, **the flapper is not checked.**

The Gas / fuel cap is also part of the inspection on tailpipe tests. You really don't need to look this up, most application guides do not list it since all vehicles came with them.

You must check fuel caps for proper application and seal. If it appears that it will not seal, like it has a cracked or missing seal, or that it is incorrect for the vehicle, such as a screw on cap on a fill pipe that requires a cap with tabs it must be failed.

You must check all fuel caps including dual or additional tanks on every vehicle during a tailpipe test if they are connected to the vehicle fuel system. Generator fuel tanks on motorhomes or supply tanks for construction equipment are not a part of this inspection. Although these should also be capped, you cannot fail a vehicle if these are not there.

Some vehicles are coming out now without fuel caps, such as:

The Easy Fuel™ capless fuel-filler system has an integrated spring-loaded flapper door that allows customers to simply insert the fuel nozzle into the tank to fill up – no removable cap is required.

Easy Fuel automatically seals after the fuel nozzle is removed – no waiting for customers to re-secure the cap – emitting fewer evaporative emissions into the environment.

Easy Fuel was introduced on the 2008 Ford Explorer and Mercury Mountaineer, and will be offered as standard equipment on the all-new 2009 Ford F-150, Ford Flex and Lincoln MKS. Ford will migrate Easy Fuel as standard across the Ford, Lincoln and Mercury passenger vehicle lineups during the next five years.

NAC 445B.580 Inspection of vehicle: Procedure for certain vehicles with model year of 1995 or older and heavy-duty vehicles with model year of 1996 or newer

...

(1) All motor vehicles subject to the provisions of this section to determine the presence of a properly installed gas cap; and

(2) Each motor vehicle with a model year of 1981 to 1995, inclusive, and, with regard to motor vehicles with a model year of 1996 or newer, each heavy-duty motor vehicle, to determine the presence of an exhaust gas recirculation system, catalytic converter, air injection system and fuel inlet restricter, and to determine whether that equipment appears to be operating in accordance with the specifications of the manufacturer of the vehicle; and

(b) Enter the results of the visual inspection into the analyzer.

...

Slide 77 Quiz, in Presentation only

Slide 78 Tamper Inspection Screen

VISIBLE SMOKE and TAMPERING			
Is Visible Smoke Being Emitted from the Vehicle?			YES
			NO
1. Air Injection System	P	Source	
2. EGR System	N	Source	4
3. Catalyst	N	Source	3
4. Fillpipe Restrictor	N	Source	2
5. Fuel Cap	P	Source	
IS THIS INFORMATION CORRECT?			
YES		NO	

After completing the tamper inspection you must confirm your entries.

Clicking "**Yes**", locks in all the information you have entered.

Once "**Yes**" has been entered no changes can be made. You cannot correct an error. If you have made an error, you must complete the test and then retest the vehicle at no charge to the customer.

A "**No**" entry will allow you to correct any errors you may have made on this screen only.

Source codes again are:

- 1 – Determination by Inspector
- 2 – Manufacturers Emission Label
- 3 – Emission Application Manual
- 4 – Other (such as electronic media)

Slide 79 Inspection Fees

Inspection Fee

ENTER THE INSPECTION FEE \$ 0.00
THIS WILL BE ADDED TO THE STATE
ADMINISTRATIVE FEE(S) AND THE
TOTAL FEE WILL BE PRINTED ON
THE VEHICLE INSPECTION REPORT.

Is this information correct?

Yes No

These are set by DMV and change periodically

1. Maximum light duty fee for Clark County is \$_____.
2. Maximum light duty fee for Washoe County is \$_____.
3. Maximum heavy duty fee for Clark County is \$_____.
4. Maximum heavy duty fee for Washoe County is \$_____.
5. Certificate fee of \$_____ is automatically added.

Slide 80 VIR Print Screen

<< >>
Prev Next
Goto
Zoom in
Fit page
Zoom out
Print
Exit

State of Nevada
Department of Motor Vehicles
Vehicle Inspection Report
ORIGINAL TEST RESULT PAGE

Printing Copy
(1/1)

This screen shows that the Vehicle Inspection Report is printing. If you need a second copy, simply click the 'print' button again.

Always check the VIR for errors. If any errors are found, retest the vehicle at no additional charge. Do not hand the invalid VIR to the customer, only the Valid VIR.

Slide 81 Valid VIR

•A VIR valid 90 days
•A VIR is a legal document!
•Except for gas cap sign off.
•Any errors = redo test
At no cost to the customer.

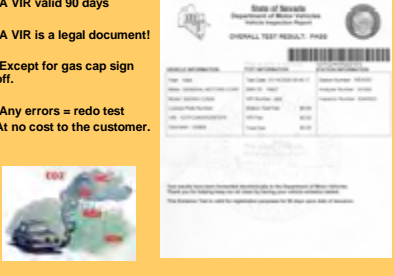

If all entries are correct you have created a valid VIR.

A valid failing VIR will allow the customer to have a challenge test performed; apply for a ten-day moving permit, or, if needed, apply for a waiver.

A valid passing VIR will allow the customer to register the vehicle.

If any errors are present on the VIR, the test must be redone at no charge to the customer.

Any Vehicle Inspection Report (VIR) is valid for 90 days, no exceptions.

Remember that the VIR is a legal document. Do not alter it in any way. Do not write on the VIR. The only exception is to sign off on a failed gas cap only on a tailpipe test.

Do not hand the VIR to the customer until you have verified there are no errors.

Issuing an invalid VIR may subject you to penalties.

Slide 82 Fuel Cap Failure

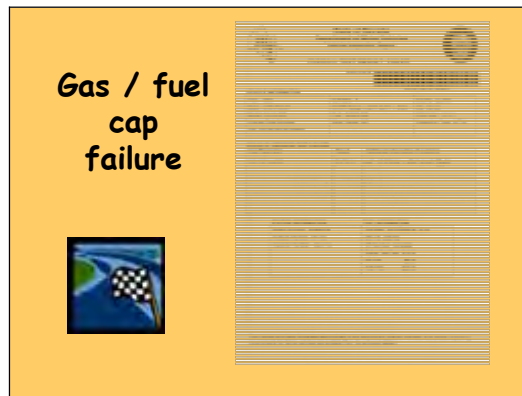

As stated previously, the only time you may write on a VIR is to sign off on a gas cap failure.

Once you have verified that the gas cap has been replaced with a correct, properly sealing gas cap you will then write your license number, the date and sign your name beneath the gas cap failure.

You do not have to be the station or the inspector that failed the vehicle to sign off on the gas cap.

Any licensed inspector can sign off on the gas cap once it has been repaired. There is no charge for this.

Remember to tell the customer that they will not be able to renew registration, electronically, by Kiosk, or by phone. They can renew by mail, dropbox, or in person only.

This is the completion of a tailpipe test.

NAC 445B.580 Inspection of vehicle: Procedure for certain vehicles with model year of 1995 or older and heavy-duty vehicles with model year of 1996 or newer.

...

7. If a motor vehicle subject to the provisions of this section passes all portions of an inspection but has an improper gas cap or no gas cap, the owner or operator of the motor vehicle shall obtain a gas cap which is in accordance with the specifications of the manufacturer of the vehicle. The inspector shall inspect the new gas cap and certify its presence in a manner prescribed by the Department, and sign and date the failing vehicle inspection report beneath the gas cap tamper description. Such a vehicle inspection report may be used as evidence of compliance.

Slide 83 OBD-II Testing

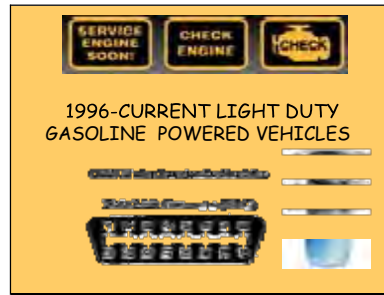

OBD-II (On Board Diagnostic) testing procedures are used on 1996 to current light duty gasoline vehicles.

This method of testing has been proven to be more effective in reducing the overall pollution levels from automobiles and is federally mandated.

OBD II testing is accomplished by using an on-board computer system (the computer [PCM] in the vehicle) that continuously monitors various Emission control related sensors, and actuators, and adjusts the air/fuel ratio for maximum performance with the lowest possible emission levels. It also triggers and stores Diagnostic Trouble Codes (DTCs) in the event a problem occurs that may increase pollution levels beyond a federal standard. These are to be used in the diagnosis and repair of emission related failures.

The goal of OBD-II testing is to catch an emission related failure before pollution levels increase and performance decreases.

If the computer (PCM/ECM) detects a fault that may cause the tailpipe emissions to exceed Federal Test Procedure standards by more than 1.5 to 2.5 times, depending on the certification, the PCM will command the Malfunction Indicator Lamp (MIL) on.

When a very severe problem exists, the MIL will flash indicating a problem currently exists that may cause catalyst damage. The vehicle should be repaired as soon as possible.

The DLC can be at various locations in the vehicle as indicated on the DLC chart, which is in the Appendix.

A reference guide will help you locate the exact position of the DLC.

Slide 84 DLC locations

SAE (the Society of Automotive Engineers) and EPA (Environmental Protection Agency) set up where the DLC was to be located, but some manufacturers did not fully understand. That's why this is necessary, although most are easily located and are in the preferred 1, 2, or 3 spots.

The DLC map is in the Appendix.

This map shows the different sections of a vehicle and gives each section a number so that if you look up the location in any guide such as the ones noted here, it will be easier to find.

Data Link Connector (DLC) locators are available at:

Weber State University: <http://www.obdclearinghouse.com> &
<http://autocenter.weber.edu.htm>

Colorado State University: (Free DLC Guide) <http://www.obdiicsu.com/>

Motor Reference Guide/Motors/Alldata: 800-332-1306 or 702-254-8561 or
dmeeter@motordms.com

Alldata: 800-697-2533)

Mitchell On Demand: 800-933-2039

Snap-On Shop Key: Contact Your Local Dealer

There are other sources as well. These sources have been verified by the DMV.

Slide 85 DLC

DLC stands for Diagnostic Link Connecter and is where the computer in the car is connected to an outside device to communicate. This is where the analyzer is connected to the vehicles PCM.

At this point you are locating the connector and checking the condition.

If the DLC is damaged or inaccessible, such as something has been mounted in front of it, or any other modification that makes it so you cannot plug in, it fails as these modifications are illegal.

If something other than "Pass through" or GPS devices, which are acceptable to EPA, has been wired in to this connector or its wiring harness, other than the

wires installed by the manufacturer, do not connect your analyzer, since damage may occur.

These modifications are illegal.

Slide 86 OBD II Monitoring Devices

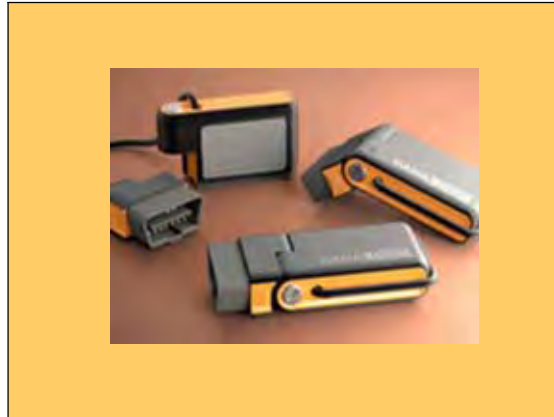

This device is one of several remote continuous OBD-2 monitoring devices currently available. They transmit emissions and other data to a central database.

These types of devices are gaining popularity, mainly for fleets. These devices are just fine to run in a vehicle, except when the vehicle needs its annual emissions test.

The vehicle fleet manager or operator will need to know they will have to remove the device for a short time in order to obtain their annual, registration enforced, emissions test.

Slide 87 OBD II Test Start

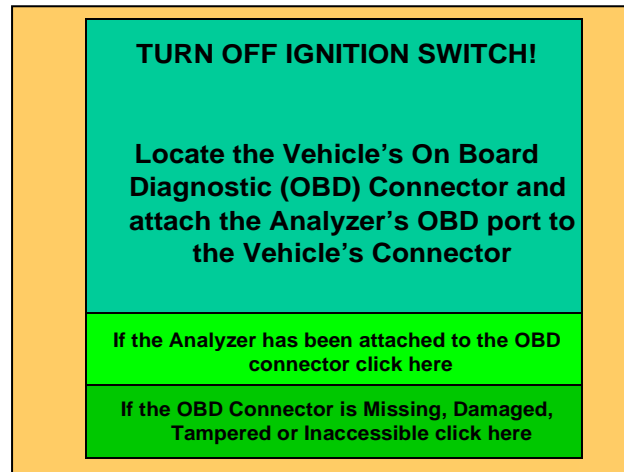

This is the screen beginning the OBD II test sequence.

The vehicle must be turned off. The screen prompts must be followed carefully.

The vehicle should remain off, with the key out, for 30 seconds. Turning the vehicle off at this point in the inspection will allow the modules to power down while you continue. Some vehicle security systems require the key be removed from the ignition in order to power down.

Using a connector reference guide if necessary, locate the OBD II connector.

If the connector is missing or damaged you must select the missing or damaged connector box entry. This will cause an overall test failure.

Be advised that DLC pin 4 (neg) and pin 16 (pos) can be very attractive to aftermarket accessory installers such as alarm, stereo, and other mobile electronics.

If any non-factory wiring is present at the DLC do not connect to your analyzer.

This does not include "Pass through" or GPS devices which are acceptable to EPA.

Some VW and Audi aftermarket audio systems may also cause a serious problem as they can send a battery voltage signal down to the DLC, so make certain the audio system is approved for the application. Damage to the analyzer is possible.

If all is acceptable, connect the analyzer OBD II plug to the vehicle OBD II connector.

Slide 88 Damaged DLC

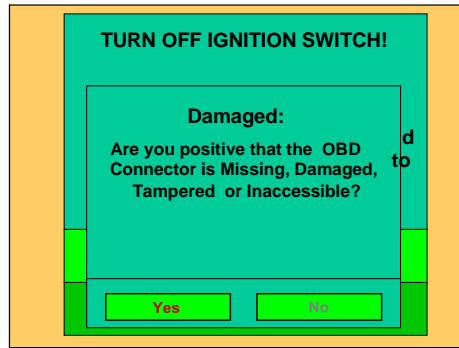

If you entered that the OBD II connector was **Missing, Damaged, Tampered or Inaccessible** on the previous screen the machine will now prompt you to confirm that entry.

Remember, if any non-factory wiring is present at the OBD-II DLC, do not connect the vehicle to the analyzer or damage to the analyzer or vehicle may result.

Refer the vehicle to the Emission Lab.

You must always follow the screen prompts carefully.

Slide 89 DLC Reason Screen

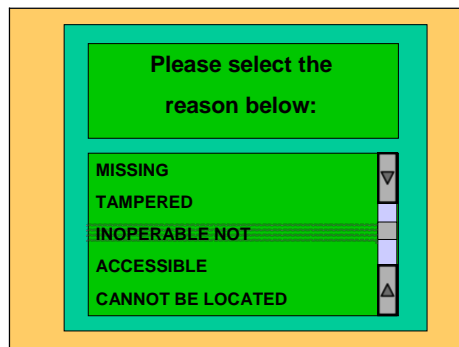

If you selected DLC **Missing, Damaged, Tampered, or Inaccessible**, you must now indicate why.

Slide 90 Chock Wheels Screen

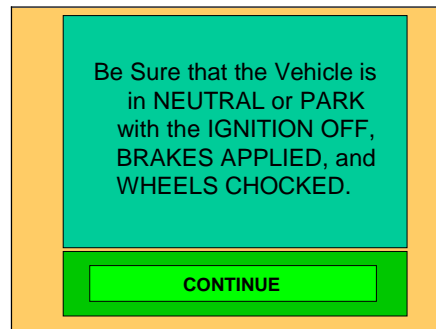

Safety First.

Be sure to place the vehicle in park or neutral, apply the brake, make sure the vehicle is off, and chock the wheels.

It is also a good idea to remove the key, for the security system.

You must follow the screen prompts carefully.

This is the law!

Slide 91 MIL Inspection

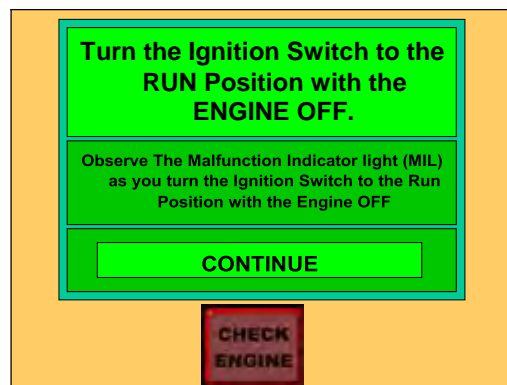

Wait at least 30 seconds with the key off and out of the ignition switch.

Then turn the ignition to the key on, engine off position (KOEO).

Observe the Malfunction Indicator Lamp. (MIL)

Slide 92 and 93 In Presentation Only

Slide 94 Keyless Ignitions

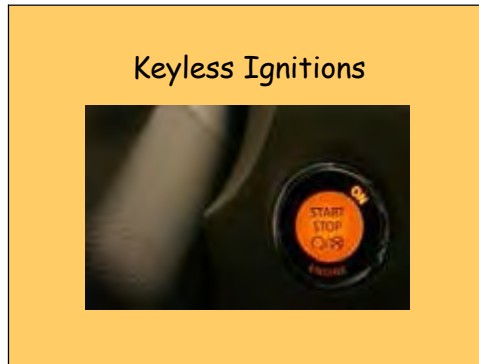

Keyless ignition systems are gaining popularity, mainly on newer, high end vehicle models.

Many of these vehicles are now just becoming subject to emission testing, as they are now over two years old.

You will conduct the MIL bulb check a little bit differently on vehicles with keyless ignition systems. Sometimes the vehicle manufacturer is the only source of information on how to run the bulb check.

Another excellent resource is the OBDII Clearinghouse:

<http://www.obdclearinghouse.com/index.php?body=can>

Slide 95 MIL Light Bulb Check

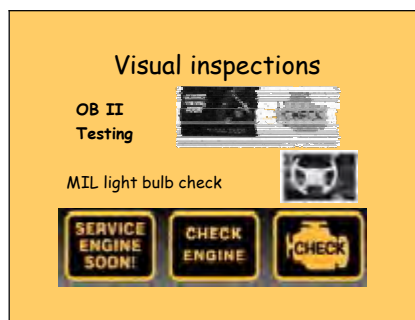

On the dash board is a warning light specifically for the emission control system.

Almost all are orange or yellow, a very few are red, such as some VWs.

All work the same way. With the engine off and the key out for at least 30 seconds, turn the key to the run position, but do not start the engine (KOEO).

The vehicle's computer will turn on the light, usually as long as the key is on and

the engine is not running, but some will only light the bulb for a very short period of time. This doesn't matter because all that is being checked is the ability of the bulb to light. You only need to confirm that the bulb has the ability to light. If it flashes on for only a split second that is OK.

NAC requires you to wait with the engine off for 12 seconds, however as stated earlier, it has been found some PCMs require up to 30 seconds to power down, some even require the key to be removed.

This may be due to the security system not allowing a full power down with the key in.

It is therefore required that you wait at least 30 seconds.

If you choose not to, you may end up with a no-communication problem, which will cause you to take even more time than the 30 seconds.

If you turn off the key and take it out of the ignition while you get the information you need from the customer and vehicle sufficient time should have passed.

Slide 96 MIL Bulb Entry Screen

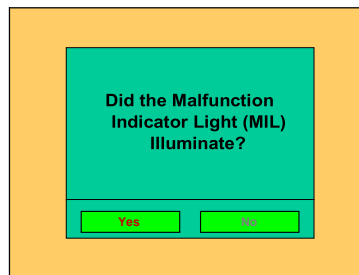

If the MIL came on or blink for any amount of time then select "**YES**".

If it did not come on or blink at all click "**NO**".

If the MIL is inoperative the vehicle will be failed and must be repaired.

Slide 97 Start the Engine

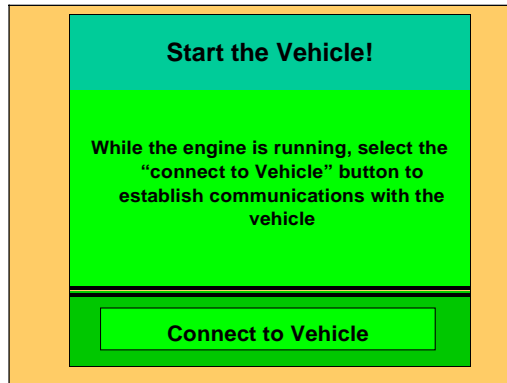

Follow the screen prompts.

Start the Engine and let it idle.

Click on the "Connect to Vehicle" box.

Slide 98 Verifying Engine Running

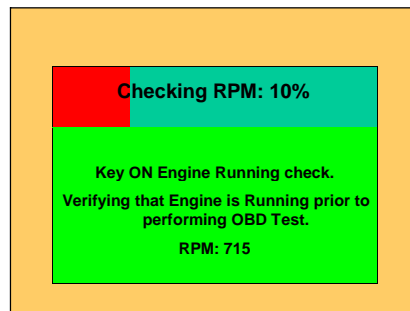

If there is no error message, the test will now continue.

The analyzer will now verify that the engine is running.

This sequence may also be a problem for some vehicles as they do not communicate RPM correctly with current software.

If no tachometer signal can be obtained thru the DLC, the vehicle will be rejected and should be referred to the Emission lab.

The RPM bar must reach 100% in order for the test to continue.

Slide 99 Error Verifying Engine Running

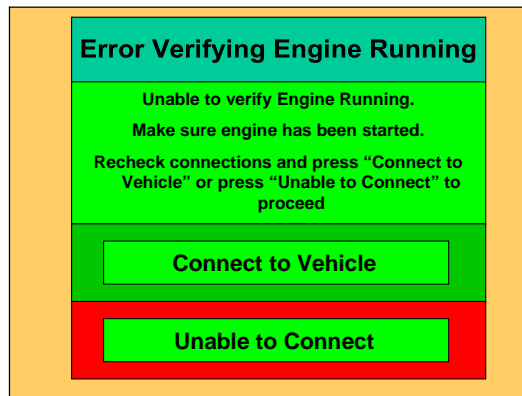

If an "Error Verifying Engine Running" comes up on the screen, check connections at the OBD connector.

Try connecting again. If the vehicle still will not communicate check the DLC connection and then try pushing the OBD II reset button on the back of the analyzer.

If no communication can be established, select "**Unable to Connect**".

The vehicle will be rejected and should be referred to the emission lab for a challenge test.

Do not send them to the dealer or anywhere else for repairs!

Slide 100 OBD II Readiness Monitors

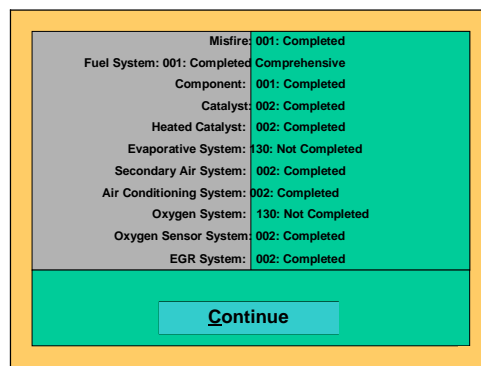

Next the OBD II readiness screen is displayed. It shows the maximum number of readiness monitors and displays the number that are actually unset.

If there are too many unset readiness monitors the vehicle will be rejected.

1996 through 2000 year model vehicles are allowed 2 unset readiness monitors.
2001 to present model year vehicles are allowed 1 unset readiness monitor.
If the maximum number of unset monitors allowed is two and the number of unset monitors is zero the vehicle test passes this portion.
If maximum number of unset readiness monitors allowed is two. The number of unset readiness monitors stored in the PCM is four the vehicle will be rejected.
The vehicle must be driven, under varying driving conditions, for three to seven days to allow the on board computer to run the readiness monitors to completion.
The vehicle must then be retested.
If the readiness monitors still have not run the vehicle must be repaired.
A drive cycle guide of the model specific drive cycle, will be made available to the customer at the Emission Lab.

Slide 101 MIL Command Status

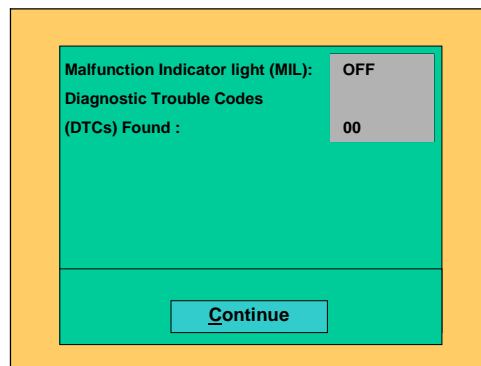

The MIL indicates DTC command status, the conditions possible are:
Commanded "Off", the vehicle passes this portion of the test.
Commanded "On", the vehicle fails this portion of the test.
Commanded to flash, the vehicle fails this portion of the test and a severe problem exists that will damage the CAT and should be repaired as soon as possible to prevent costlier repairs and excess pollution.
If the MIL is commanded off but codes are stored, will this cause a test failure?
No. Inactive codes or codes that were not cleared after a previous repair will not cause a test failure.
Only active codes that command the MIL on will cause a test failure.

Slide 102 DTC Display

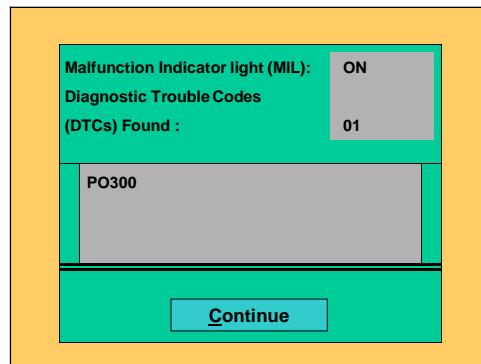

If the MIL is commanded on, the diagnostic trouble code or codes will be displayed on this screen.

2G shops can translate these codes using an OBD II reference guide book. Do not clear codes. A 1G shop is prohibited from erasing DTCs. Important diagnostic freeze frame data will be lost if codes are cleared.

It is a violation of NAC (445B.463) for a 1G station to intentionally remove data from any diagnostic system.

After diagnosis and repair, the DTC may be cleared. The 2G repair shop should then run the vehicle until that monitor has run to completion and the system has passed. The system that diagnosed the problem in the first place verified the repair, so if the light comes on now, it must be a new, unrelated problem. Remember any DTC that can illuminate the MIL must, by law, be emission related. So if the DTC is for a transmission, brake, suspension or any other system not usually known to be an emission system, rest assured it is something that could cause an emission failure or it would not be allowed to turn on the MIL. If a transmission can't shift out of third gear, it is polluting more than it should going down the highway at 70 MPH. If the ABS wheel speed sensor is used to diagnose misfire, which is very common, and it fails, this could cause a misfire to go undetected so this also is emission related. Some vehicles use a chassis mounted sensor to detect and adjust vehicle height and ride control on rough roads, this can also be used by the vehicle in misfire diagnosis. The bottom line is, if it commands the MIL on, it is emission related.

NAC 445B.463 Test station: Grounds for denial, revocation or suspension of license; reapplication; permanent revocation of license.

1. Each of the following acts, omissions and conditions may constitute a ground for the denial of an application for a license to operate a test station or for the revocation or suspension of such a license:

...

2. In addition to the acts, omissions and conditions set forth in subsection 1, any attempt to alter the readings obtained during a test of exhaust emissions or to modify or remove the data obtained by an exhaust gas analyzer or a certified on-board diagnostic system may constitute a ground for the revocation or suspension of a license to operate a test station.

Slide 103 OBD II and Smoke

Smoke is checked only at **idle** at the **tailpipe only** on OBD II testing.

It is only checked at the **tailpipe**, not under the hood.

Slide 104 Smoke Entry

The image shows a screenshot of a software interface for recording inspection results. It features a yellow border and a central grey box. At the top of the grey box, the text reads "VISIBLE SMOKE / TAMPERING". Below this, a question is displayed: "Is Visible smoke Being Emitted From The Vehicle?" followed by a small input field containing the letter "N". At the bottom of the grey box, the text reads "Y - YES, N - NO".

if the vehicle was smoking at any time during the test enter a “Y” for Yes

If not enter an “N” for NO.

A “Y”es entry will cause an overall test failure.

Smoke must be coming from the tailpipe.

NAC 445B.5805 Inspection of vehicle: Procedure for light-duty vehicles with model year of 1996 or newer.

1. The provisions of this section apply to inspections of light-duty motor vehicles with a model year of 1996 or newer.

2. After the owner or operator of a motor vehicle subject to the provisions of this section requests an inspection, the inspector shall:
 - (a) Turn the ignition switch to the off position for at least 12 seconds.
 - (b) Locate the data-link connector for the vehicle and connect the test equipment.
 - (c) Visually inspect the operation of the malfunction illumination light while turning the ignition switch to the run position with the engine off.
 - (d) Start the vehicle and, with the engine running, establish communication with the certified on-board diagnostic system installed in the vehicle.
 - (e) Visually inspect the vehicle to determine whether the malfunction illumination light is commanded on.
 - (f) Review the emission readiness code status.
 - (g) Retrieve all data trouble codes that are present.
3. The inspector shall complete each test and issue a vehicle inspection report indicating whether or not the vehicle passes the inspection.
4. The inspector shall issue a vehicle inspection report indicating that the vehicle did not pass the inspection if:
 - (a) The vehicle has a malfunction illumination light that fails to illuminate during a visual inspection while the ignition switch is turned to the run position with the engine off;
 - (b) The vehicle has its malfunction illumination light commanded on continuously;
 - (c) The vehicle has a data-link connector that is missing, has been tampered with or is inoperable, including related electrical circuitry;
 - (d) There is no serial data communication from the certified on-board diagnostic system installed in the vehicle;
 - (e) The vehicle has a model year of 2001 or newer and has more than one unset readiness indicator;
 - (f) The vehicle has a model year of 1996 to 2000, inclusive, and has more than two unset readiness indicators; or
 - (g) Smoke is visible in the exhaust emissions from the vehicle with the engine speed at idle.

Slide 105 Test Fees

Inspection Fee

ENTER THE INSPECTION FEE \$ 0.00
THIS WILL BE ADDED TO THE STATE
ADMINISTRATIVE FEE(S) AND THE
TOTAL FEE WILL BE PRINTED ON
THE VEHICLE INSPECTION REPORT.

Is this information correct?

Yes No

Current Maximum Test Fees-

The maximum light duty fee that can be entered in the analyzer is:
for Washoe County: is \$____. and
for Clark County is \$____.

The maximum heavy duty fee that can be entered in the analyzer is:
for Washoe County: is \$____. and
for Clark County is \$____.

The analyzer automatically adds the \$_. VIR fee

Slide 106 End of OBD II Test

The OBD II inspection is complete.

A sample Passing VIR is in the Appendix

Turn off the engine before you disconnect the analyzer to prevent damage to either the analyzer or the vehicle.

Check your VIR for accuracy. If you find you have made any errors you must retest the vehicle at no charge to the customer.

Do not write on your VIRS. Any alterations on a VIR may subject you to penalties.

As with the tailpipe test, you may print additional copies of the VIR if desired.

If there are any errors and the entire test must be done over again at no cost to the customer.

Do not hand the VIR to the customer until you have verified there are no errors.

Issuing an invalid VIR may subject you to penalties.

Communicate with the customer, let them know if they passed, failed or were rejected for testing.

Do not send the customer in to DMV Registration with a failing VIR.

Send your customer to the Emission Lab if needed.

Slide 107 Reject VIR

A sample of a reject VIR is in the Appendix.

It has too many unset readiness monitors.

Remember this is not a fail because the tests have not yet been run to completion so that we do not know whether they will fail or not.

A REJECT test will not begin the waiver process.

A Reject test may, allow for a moving permit.

Slide 108 Fail VIR

A sample of a Failed VIR is in the Appendix. Notice that it will list failing items.

Slide 109 Failing Test

A failed test is useful because it allows issuance of 10-day moving permits, It allows a customer to get a challenge test at the emission lab, whether the vehicle failed for smoke, tampering, HC/CO, or OBDII or the customer is simply unconvinced, and a Failed test is the beginning of the waiver process.

Slide 110 Waivers

A sample Waiver printout is in the Appendix.

A waiver permits the registration of the vehicle.

Only the DMV Emission Lab may grant a waiver.

The DMV Emission Lab will deny an application for a waiver if the parts have not been installed or the repairs performed as indicated on the receipts presented to the DMV Emission Lab.

The Department will allow registration of the vehicle if The Department finds after inspection, that additional costs exceeding the minimum established in this section are needed to bring the vehicle into compliance.

A vehicle under a warranty covering the affected components is not eligible for a waiver.

All qualifying repairs must be performed at a licensed Authorized Station (2G), except in Washoe County where self repairs, repairs performed by the owner, are allowed.

No waivers are allowed for smoking vehicles, these must be repaired regardless of the cost.

Repairs to required emission devices and repairs done to systems not directly related to the emission failure will not count toward the minimum expenditures. In Clark County the minimum repair expense requirement is \$450, not including the costs of the emission tests, only at a 2G station.

In Washoe County the minimum repair expense requirement is \$200, not including the costs of the emission tests, either at a 2G station or in self repairs, parts only.

To be considered for a self repair waiver in Washoe County, proof that the minimum of \$200 has been spent and the parts purchased within 14 days of the initial failing test.

Waiver applications must be presented by the customer at the local Emission Control Lab and must include; the failing vehicle, all receipts to document the repairs if at a 2G shop, receipts for the installed parts if a self repair in Washoe County, the failing VIR from before the repairs, the failing VIR from after the repairs.

The issuance of a waiver is not guaranteed and there are no waivers from smoking failures and tamper failures.

NAC 445B.590 Waiver of standards for emissions.

1. Only the Department may grant a waiver from the standards for emissions as set forth in subsection 3 of [NAC 445B.576](#) or in [NAC 445B.596](#).

2. An application for a waiver from the provisions of [NAC 445B.596](#) for a motor vehicle powered by gasoline that is subject to an inspection pursuant to:

(a) [NAC 445B.594](#) must include receipts from an authorized station that at least \$200 has been spent on parts other than a catalytic converter, fuel inlet restricter or air injection system or on labor other than emission testing if the repairs evidenced by the receipt were directly related to the deficiency in emissions. If the vehicle is repaired by the owner, the application must include receipts or other evidence that at least \$200 has been spent on parts other than a catalytic converter, fuel inlet restricter or air injection system purchased within 14 calendar days after the initial emissions test. No allowance will be permitted for labor on vehicles repaired by the owner.

(b) [NAC 445B.593](#) must include receipts from an authorized station that at least \$450 has been spent on parts other than a catalytic converter, fuel inlet restricter or air injection

system or on labor other than emission testing if the repairs evidenced by the receipt were directly related to the deficiency in emissions.

3. Except as otherwise provided in subsection 4, an application for a waiver for a light-duty motor vehicle powered by a diesel engine from the provisions of subsection 3 of [NAC 445B.576](#) must include:

(a) A copy of the original certificate indicating that the vehicle failed to comply with the provisions of subsection 3 of [NAC 445B.576](#); and

(b) Receipts or other evidence that at least \$750 has been spent on:

(1) Parts other than required emission control equipment; or

(2) Labor other than emission testing if the repairs evidenced by the receipt were directly related to the deficiency in emissions.

↔̄ Receipts must be dated within 14 calendar days after the date of issuance of the certificate indicating that the vehicle failed to comply with subsection 3 of [NAC 445B.576](#).

4. If the owner of a light-duty motor vehicle powered by a diesel engine repairs the vehicle, an application for a waiver from the provisions of subsection 3 of [NAC 445B.576](#) must include:

(a) A copy of the original certificate indicating that the vehicle failed to comply with the provisions of subsection 3 of [NAC 445B.576](#); and

(b) Receipts or other evidence that at least \$500 has been spent on parts other than required emission control equipment. No allowance will be permitted for labor on a vehicle repaired by the owner.

↔̄ Receipts must be dated within 14 calendar days after the date of issuance of the certificate indicating that the vehicle failed to comply with subsection 3 of [NAC 445B.576](#).

5. The Department will deny an application for a waiver if the parts have not been installed or the repairs performed as indicated on the receipts presented to the Department.

6. The Department will allow registration of the vehicle if:

(a) The provisions of [NAC 445B.582](#) have been complied with; and

(b) The Department finds after inspection that additional costs exceeding the minimum established in this section are needed to bring the vehicle into compliance.

7. A vehicle which qualifies for repairs under a warranty is not eligible for a waiver.

8. A waiver permits the registration of the vehicle.

Slide 111 Rejects

A sample Reject printout is in the Appendix.

A reject test result could be caused by any of several different things, depending on the type of test that was required.

On an OBDII test (1996 and newer light-duty test) the most common cause is uncompleted monitors.

To complete monitors, the vehicle needs to be driven.

Other possible causes are that the Data Link Connector is inoperable, not accessible, or cannot be located.

On a Two Speed Idle test (1995 and older light duty, and all heavy duty), exhaust sample dilution and unstable or high RPM can both cause reject results.

Note: The emission station is not charged the \$6.00 VIR fee on any reject test and cannot legally collect it from the customer.

If necessary refer them to the Emission Lab for assistance.

Slide 112 Alternative Registration Renewal Services

Emission Inspectors are encouraged to inform the customer of Alternative Registration Renewal Services. It not only reduces lines at DMV offices, but also helps emission station customer satisfaction.

The State of Nevada DMV now provides alternative registration renewal services to the consumer. Online @ www.dmvnv.com; By Phone @ 775-684-4368 or 702-486-4368; By Mail; in a Drop Box inside the DMV offices; At a Kiosk located inside most DMV offices; or At an Emission Station that is enrolled in the renewal program

Slide 113 and 114 Important Contacts

Las Vegas	Reno	Emission Training Officer
Emission Control Lab	Emission Lab	Hal Greene
702-486-4981	775-684-3580	702-486-4999
Smoking vehicle hotline	Smoking Vehicle Hotline	hgreene@dmv.nv.gov
702-642-7664 (SMOG)	775-686-7664 (SMOG)	

Slide 115 Closing Statement

You are the frontline Representative for Nevada's clean air program. It is vitally important that you are knowledgeable about the emission program, the emission test and results and the emission analyzer. It is especially important if you repair vehicle emission systems.

Your ability to diagnose and correct problems is crucial to Nevada's efforts to improve its air quality.

Slide 116 and 117 Test Taking Tips

First recognize the inherent advantage of having four answer choices right there in front of you, the correct answer is already there and all you have to do is find it!

Have a Positive Attitude: "I can do this!!"

On multiple choice tests you may not always be given the perfect answer. You must choose the best answer.

Eliminate answers you know or can prove wrong.

Read all the answers, even if the you believe you have found the correct answer first.

Read the question and then only one answer, do this for each answer.

Guess if you have to, 25% chance is better than 0%

If you have to guess, eliminate as many wrong answers as possible first.

On True – False questions

50 – 50 chance if you just guess!

Usually one is opposite of the other.

It probably hinges on one word or phrase.

You just need to prove it wrong, that is easier than proving it right!

Tech A vs. Tech B questions

These look dangerous and complicated, after all there are usually two long statements you have to read through, but really these are almost as simple as True or False. OK they are as easy as TWO True false questions because that is what they are.

Read Tech A first and realize he is either right or wrong so his statement is either True or false.

Do not read the other techs statement until you decide on Tech A. Then do the same with Tech B's statement, it is either True or false.

The answers will be:

- (a) Tech A only
- (b) Tech B only
- (c) Both Tech A and Tech B.
- (d) Neither tech A nor Tech B

Read the entire test through and look up anything you can.

Slide 118 Testing Rules

1. There is to be no marking in the test booklets. Each will be checked and any marks found will result in invalidating that applicant's examination and they will be required to reschedule and retake the class and test. If your test booklet is marked in, immediately bring it to the instructor's attention, so that you will not be penalized.
2. Read all instructions in the test booklet, all provided information is available for reference, this is an open book test.
3. Be sure to look up any item that is possible to look up.
4. Take your time, don't assume your recollection of the material is correct, some questions are meant only to test your ability to look things up and determine what means are best to do this. The answers may be identical, except for one or two words.
5. The instructor may not assist you in answering a question. However they may assist you in understanding a question.

Security rules: No cell phones, if you brought one, place it in silent mode on the table in front of you or in your car, you may not make nor accept any calls during the test, this includes text messaging. No camera phones, if you have a camera phone hand it over to the instructor before beginning the test, or put it in your car. If a call comes in that you feel you must accept, turn in your paperwork and reschedule the class and exam.

No looking at another's answers, they are probably worse than yours anyway. If you are observed either looking at another's answers or showing another your answers you will be failed and must reschedule.

No talking during the test, if caught you will be failed and must reschedule.

Reporting: the exam score is only available to the applicant. No information will be given to a third party unless agreed to, in writing, by the applicant.

Appendix

Fine Schedule		
Covert	Inspector	Station
First	C&D order and attend DMV conducted course	Written Notice
Second	\$250.00 fine + DMV approved course at DMV approved provider + 10-day suspension	Owner or representative to complete educational course conducted by DMV
Third	\$500.00 fine + 90-day suspension	\$1000 fine
Fourth	Permanent Revocation	Permanent Revocation
Non Covert	Inspector	Station
First	\$100 - \$500	\$100 - \$500
Second	\$500 - \$1,000	\$500 - \$1,000
Third	\$1,000 - \$1,500	\$1,000 - \$1,500
Fourth	\$1,500 - \$2,500	\$1,500 - \$2,500
Willful, intentional, or violations involving fraud, are subject to more immediate and serious consequences as allowed by law.		
When a C&D or written notice is issued in lieu of a fine, it still counts as a first violation.		

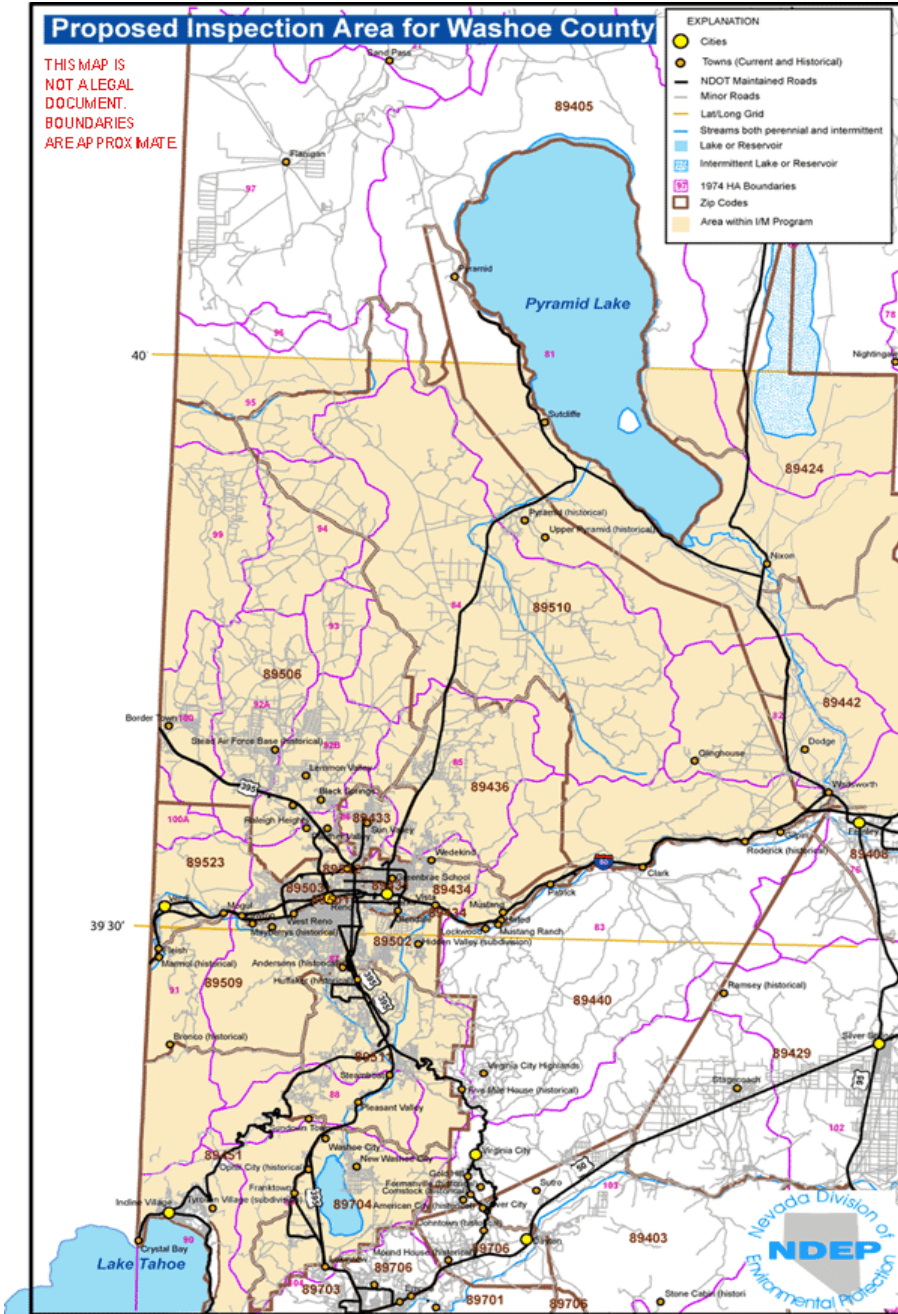

Exempt Areas; Exempt areas:
 Crystal Bay
 Nixon
 Wadsworth
 Empire
 Incline village
 Sutcliffe

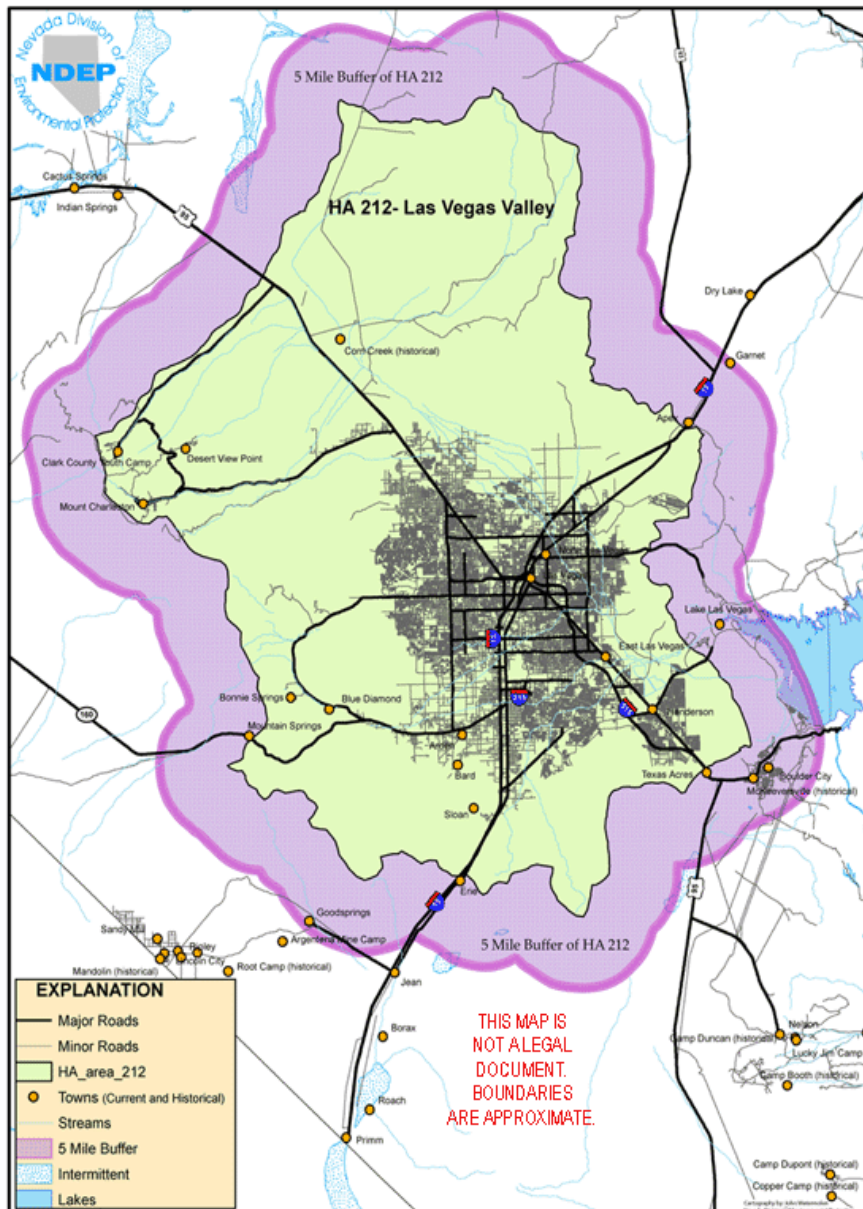

Exempt areas:
Goodsprings



Training checklist

Please Read:

Below is the procedure for performing the Demonstration on the Emissions Analyzer and the Practical Demonstration of an Emission Inspection. There is a two (2) hour time limit to complete this examination.

This examination consists of four parts:

- a) Analyzer Demonstration
- b) Pre-inspection
- c) Performing the inspection; and
- d) Post inspection review.

Once you start entering information into the analyzer, during the practical Demonstration portion, you will **not** be allowed to ask questions of the administering technician. The technician will perform the role of the customer, and a customer is not expected to answer technical questions. Ask any and all questions prior to the beginning of the examination. You will be scored on each question. Some questions will be simply "Satisfactory" or "Unsatisfactory", others will carry an "Advisory" value. You are required to score twenty (20) "Satisfactory" out of twenty five (25) possible on the Analyzer Demonstration in order to pass and proceed. If you receive one "Unsatisfactory" on any portion of the Practical examination, the exam will be failed as a whole, but will continue until complete, except for reasons such as safety or the time limit, in order to give the most complete evaluation possible.

This is also the **TRAINING CHECKLIST**. Do not mark any item as complete until you are satisfied that you understand the item and can perform the actions required.

ANALYZER DEMONSTRATION

- [] 1. Access printer
- [] 2. Check printer settings
- [] 3. Add paper
- [] 4. Power up analyzer
- [] 5. Access Main Menu
- [] 6. Explain Vehicle Inspection selection
- [] 7. Explain Vehicle Diagnostics selection
- [] 8. Explain Analyzer Maintenance selection
- [] 9. Explain Station Manager selection
- [] 10. Explain State Audit selection
- [] 11. Explain Service Menu selection
- [] 12. Explain System Shutdown selection
- [] 13. Explain the "A" reset button and "Computer reset" button.
- [] 14. Access Training Mode
- [] 15. Access RPM Screen & Demonstrate 3 Methods to Obtain a Signal
- [] 16. Access and explain 4 Gas selection
- [] 17. Access and explain OBD II Manual Mode selection
- [] 18. Access and explain RPM selection

- [] 19. Demonstrate connection and disconnection of dual probes, and explain use.
- [] 20. Access and explain Gas calibration
- [] 21. Access and explain Leak Check
- [] 22. Access and explain Status screen
- [] 23. Access and explain Network Diagnostics
- [] 24. Change calibration gas bottles (verbal explanation acceptable)
- [] 25. Perform Maintenance on filters, screens & traps

PRACTICAL EXAMINATION SCORE SHEET
PRE-INSPECTION PROCEDURE

- [] 1. Perform a three day calibration
- [] 2. Perform a Leak Check of the analyzer sample system
- [] 3. Enter Status Screen
- [] 4. Perform or explain Data File Refresh

VEHICLE INFORMATION ENTRY

- **At this point the time begins on the analyzer. There is a thirty (30) minute time limit for this portion of the examination.**

Follow all prompts on the screen including but not limited to:

- [] 1. Enter I/M test mode (Select correct icon on analyzer screen)
- [] 2. Why is an inspection necessary? (County, City, Zip code, tested in last 90 days, Etc.)
- [] 3. Ensure the vehicle is at operating temperature (gauges, hoses, etc.)
- [] 4. Enter Inspectors USER ID
- [] 5. Enter Inspectors PASSCODE
- [] 6. Enter VIN from proper location
- [] 7. Enter license plate type (1-NV, 2-Non-NV, 3 No plate)
- [] 8. Enter license plate number
- [] 9. Enter License Plate State
- [] 10. Select No Plate Reason, if applicable
- [] 11. Enter zip code
- [] 12. Enter county vehicle based
- [] 13. Enter if vehicle is a motor home
- [] 14. Enter if gross vehicle weight is over / under 8499
- [] 15. Enter odometer mileage

- **CONNECT ANALYZER TO VEHICLE INFORMATION DATABASE**

- [] 16. Enter vehicle year if prompted
- [] 17. Enter vehicle model if prompted
- [] 18. Enter vehicle make if prompted
- [] 19. Enter number of cylinders if prompted
- [] 20. Enter fuel type if prompted

- **TWO SPEED IDLE (TSI) TEST PROCEDURE**

- [] 21. Enter type of ignition
- [] 22. Enter dual or single exhaust
- [] 23. Enter AIR equipped (for dilution standards)
- [] 24. Enter under-hood emission label information
- [] 25. Ensure all accessories are off, parking brake set and wheels chocked
- [] 26. Insert probe(s) properly
- [] 27. Attach Tachometer lead and obtain a stable RPM reading
- [] 28. Perform the 2500 RPM portion of the test
- [] 29. Perform the idle portion of the test

- [] 30. Perform a second chance test if needed
- [] 31. Perform visual verification of smoke at Idle and 2500 RPM
- [] 32. Perform a tampering inspection for secondary Air Injection
- [] 33. Perform tampering inspection for EGR system
- [] 34. Perform tampering inspection for Catalytic Converter(s)
- [] 35. Perform tampering inspection for Fuel Inlet Restrictor
- [] 36. Perform tampering inspection for proper sealed gas cap
- [] 37. Properly Enter Inspection Fee
- [] 38. Print correct Vehicle Inspection Report
- [] 39. Verbal explanation of test results.

ONBOARD DIAGNOSTICS TWO (OBD II) TESTING

- [] 1. Enter under-hood emission label information
- [] 2. Locate & connect to DLC & explain missing, damaged or inaccessible
- [] 3. Chock wheels, place in park or neutral, Etc.
- [] 4. Key On Engine Off, did the MIL light?
- [] 5. Start Engine & click Connect to Vehicle
- [] 6. If error connecting comes up then what? (Press OBD Reset, Retry etc.)
- [] 7. Readiness monitors, if too many then what? (Rejected Test?)
- [] 8. MIL status and DTC screen
- [] 9. Is the vehicle smoking? Yes or no
- [] 10. Properly Enter Inspection Fee
- [] 11. Print correct Vehicle Inspection Report
- [] 12. Verbal explanation of test results.

POST-INSPECTION REVIEW

- [] 1. Verbal explanation of a tampering failure
- [] 2. Verbal explanation of a smoking failure
- [] 3. Verbal explanation of a tailpipe failure
- [] 4. Verbal explanation of the waiver requirements in both Clark and Washoe counties
- [] 5. Verbal explanation of components, probable location and operational need for the secondary Air Injection system
- [] 6. Verbal explanation of components, probable location and operational need for the EGR system
- [] 7. Verbal explanation of components, probable location and operational need for Catalytic converter
- [] 8. Verbal explanation of the operational need for the Fuel Inlet Restrictor
- [] 9. Verbal explanation of the operational need for the Gas Cap
- [] 10. Look up vehicle #1_____for required equipment
- [] 11. Look up vehicle #2_____for required equipment
- [] 12. Look up vehicle #3_____for required equipment
- [] 13. If Not Done Previously, Demonstrate Three Methods to get a Tach signal

I have been instructed on all the above items checked off.

Signature of applicant

Date

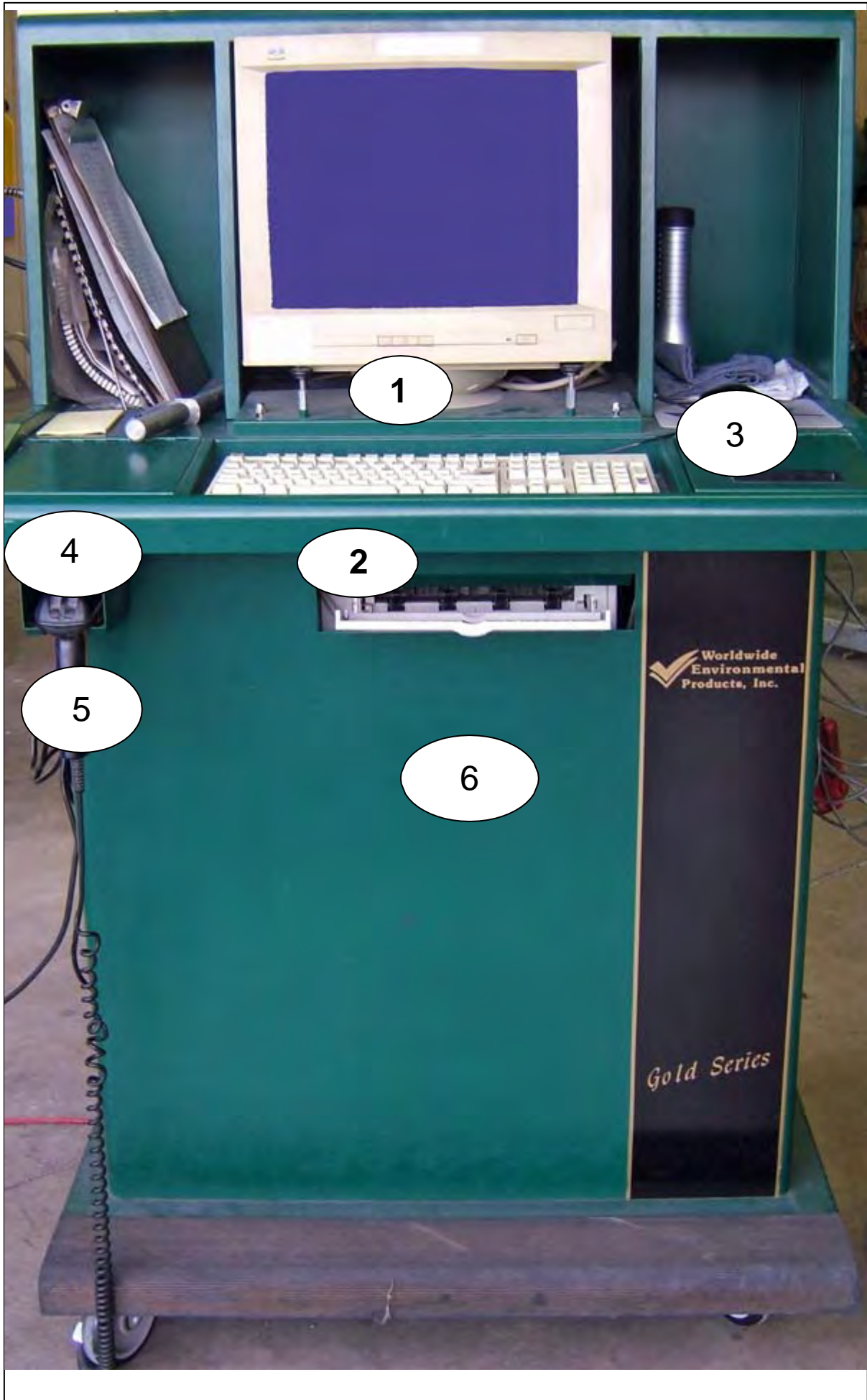

1

3

4

2

5

6

Worldwide
Environmental
Products, Inc.

Gold Series

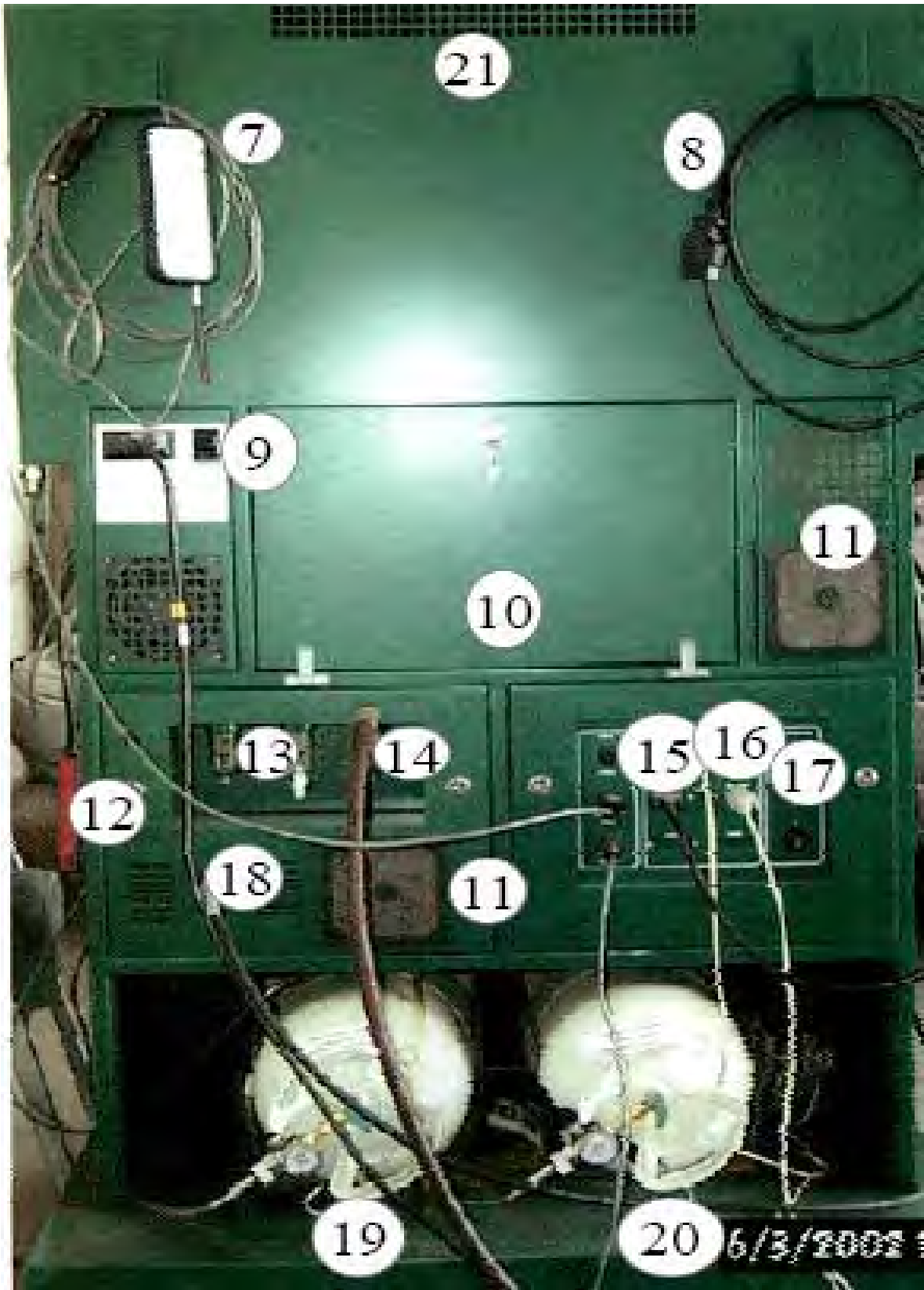

INDEX

1. MONITOR
2. KEYBOARD
3. MOUSE
4. CD/ROM
5. BAR CODE SCANNER
6. PRINTER TRAY
7. NON-CONTACT TACH LEAD
8. OBD II DLC LEAD
9. MAIN POWER SWITCH & CORD
10. PRINTER ACCESS
11. FANS & WASHABLE FILTERS
12. CONTACT TACH LEAD
13. SAMPLE HOSE & BENCH FILTERS
14. SHOP AIR INLET (80 – 100 PSI) & FILTER
15. OBD RESET BUTTON
16. COMPUTER RESET BUTTON
17. "A" BUTTON (SYSTEM RESTART REQUIRES WARMUP)
18. SAMPLE HOSE & PROBE
19. HIGH CAL GAS BOTTLE & REGULATOR
20. LOW CAL GAS BOTTLE & REGULATOR (GREEN STRIPE)
21. MONITOR VENT (DO NOT BLOCK)

Single Exhaust Diagram

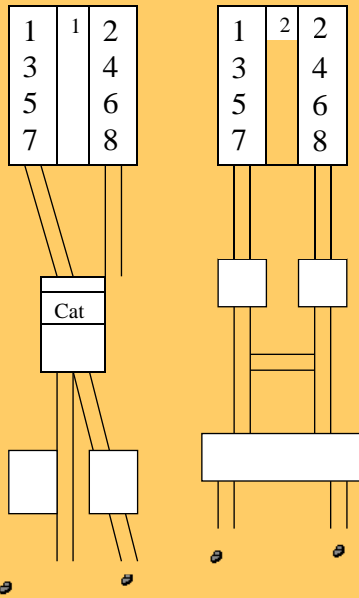

Dual Exhaust Diagram

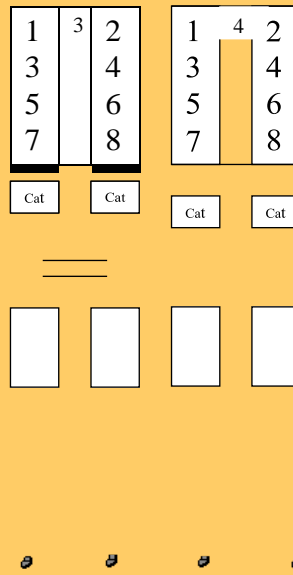

Looking at the dual exhaust diagrams, we can see that if we have misfire on cylinder #8, and are only sampling the left exhaust pipe, the vehicle would likely pass. Tested correctly, (with both probes), it would likely fail.

Looking at the single exhaust diagrams, with the same cylinder #8 misfire, where all the exhaust is forced to intermix in the catalytic or the muffler, the vehicle would likely fail.

It is the inspector's responsibility to make a correct determination as to whether the vehicle is single or dual exhaust.

Please note that in at least one configuration #1 could still be dual exhaust since the catalytic shell contains two separate Cats

If in doubt, test the vehicle as dual exhaust.

TACH SIGNAL NOTES

When trying to locate a tachometer signal on a vehicle, try to think of all the options available. Too many Techs go straight to the non contact RPM pickup if spark plug wires are not available.

The best options are:

- The OBD II connector (1st choice)
 - Click on OBD II from the tachometer screen and follow the prompts.
- The Red Contact Pickup (2nd choice)
 - Does the automotive manufacturer provide a tachometer loop? You can connect the red contact lead to the loop.
 - Try the red contact lead on the wires going to an individual coil.
 - Try the red contact lead on a fuel injector harness.
 - Try the red contact lead on various harnesses in the engine compartment that may carry a tachometer pulse, fuel injector pulse or a coil pulse.
 - Opening the non-contact red pickup and laying it in various areas of the engine compartment can obtain some signals. (Volvo inline 6 cylinder on rear of valve cover)
 - Remember the range and sensitivity adjustments on your Worldwide tachometer screen can be used to fine tune your tachometer signal.
 - Put the cursor on the desired arrow (range or sensitivity) left click and hold while moving the arrow. When you release the mouse you can verify that your rpm reading is within the desired range. If it is still not within range repeat the above process.
 - For hard to get wiring Worldwide provides a green wire loop that can be wrapped around various harnesses, coil and/or injector wires and clipped with the red contact lead to obtain a tachometer signal.
 - Look for igniter packs on some vehicles. These igniter packs often have signal wires that can be utilized to get a tachometer signal using the red contact lead. Sometimes this also requires the use of the green Worldwide wire loop. (Infinity & Nissan)
 - While trying to get a tachometer signal keep in mind you may need to change a DIS or coil over plug vehicle to four cycle or a four cycle to DIS to bring the RPM's into range. Don't be afraid to experiment.
 - When looking for a tachometer signal on 1998 and newer heavy-duty vehicles remember some have OBD II data link connectors. While we are not performing OBD II tests on heavy-duty vehicles this may be a quick and easy source for a tachometer signal.

Non-Contact (last choice)

- Antenna type (Must be set on four cycle)
 - Try placing the antenna as close as possible to a signal source. This could be a spark plug, coil, fuel injector, wiring harness or fuse box. Slight movement could make a big difference in the signal pickup.
 - Remember the range and sensitivity adjustment also works with this pickup. To adjust the range and sensitivity from the tachometer screen left click and hold on the desired adjustment arrow and drag the arrow to the estimated position. Release and verify the reading is within range. If not repeat.

- Make sure the area you put it in is free of moving objects and that the non-contact probe will not vibrate out of position or fall into an unsafe area of the engine compartment.
- The new optional adjustable non-contact pick-up (Must be set on four cycle)
 - Try locating the probe near a good pulse source. This may be a fuel injector coil, ignition module, fuse box or wiring harness.
 - Once a signal is obtained try fine tuning the pick-up by using the three position sensitivity switch on the side of the pick-up and the range and or sensitivity adjustments on your Worldwide tachometer screen. (Moving the cursor to the range or sensitivity indicator, clicking the mouse and dragging the indicator to the desired position can change the range and sensitivity)
 - Be aware that by rotating the probe box or flipping it upside down you may get a signal. Try rotating 90 degrees at a time.
 - Some non traditional areas to get tachometer signal with the new optional pick-up are:
 - Windshield just above the instrument cluster. (Nissan Maxima)
 - On top of the fuse box. (BMW 735 left front with the probe sensitivity switch set to the center position and probe wiring pointing to the front of the car.)
 - On top of the valve cover (GM QUAD FOUR VEHICLES)
- Make sure you verify both the high and low RPM tachometer signals before proceeding to the test stage. Many vehicles will display a good tachometer signal at low RPM but may display a false signal at high RPM. Remember, if you proceed to the test stage and the customer should experience a false failure due to a bad tachometer signal you will be required to retest the vehicle at no charge to the customer.
- It is to your advantage to try your best to get a tachometer signal before inconveniencing a customer and sending them away. The average time to locate a tachometer signal at the Reno Emission Lab is less than 5 minutes.

In closing, remember to always work safely. Don't put your hands or arms in harms way and don't place your probes or cords in an area of extreme heat or where moving parts may damage or destroy them.

./ Some tips are:

Y **Astro Vans**: Non-antenna type non- contact pick-up placed on the drivers side floor under the brake pedal.

Y **1991 Lexus LS 400**: Non-antenna type pick-up placed on the drivers floor under the brake pedal.

Y **1990 Infinity**: Red contact lead clipped to wire below the igniter unit located on drivers side valve cover just to the engine side of the brake master cylinder.(One wire going into a large white connector)

Y **1992 Previa**: Under drivers seat, on the left side. Use the antenna type non-contact pick-up with the antenna fully retracted. Insert the tip of the pick-up behind the Toyota factory data plug.

- Y **1994 Audi:** Red contact lead on top of valve cover near firewall. Set on four cycle. (This may require that the red contact lead be either open or closed but remember it is not clipped to anything)
- Y **2000 BMW 320CI:** Some will need to be re-flashed in order to communicate with the OBD- II port. (Send to dealer)
- Y **1993 BMW:** Non-contact non-antenna type placed upside down cord pointed up directly in front of the positive battery connector.
- Y **1992 BMW 525 I:** Non-contact non-antenna type on the drivers side of the engine compartment on top of the fuse box with the wire pointed forward. (Set the sensitivity switch to the center position)
- Y **1995 BMW:** Non-contact non-antenna type pick-up on the passenger side fuse box. Wire pointed forward with sensitivity set to the lowest setting. Adjust range and sensitivity and verify both high and low RPM.
- Y **1990 Chevy Quad 4:** Non-contact non-antenna type pick-up placed on the black box just in front of the valve cover on the drivers side.
- Y **1994 Infinity Q45:** Red contact lead connected to black wire with large plastic connector on top of passenger side valve cover. (Set analyzer on contact/four cycle.)
- Y **1995 Jaguar XJ6:** Use the red contact lead by wrapping the Worldwide provided green wire loop around the large harness directly behind the valve cover at the firewall. (Set on 4-cycle)
- Y **1995 NISSAN MAXIMA:** Non-contact non-antenna type pick-up placed upside down on black cover at the drivers side of the front valve cover just forward of the throttle body.
- Y **1990 Nissan 300SX Turbo:** Red contact lead on top of passenger side front coil bank (in between intake manifold runners) with the contact lead open.
- Y **1991 Pontiac Quad 4:** Red contact lead clipped to the brown wire with the black tracer going into valve cover. Set on four cycle and adjust range to give you 700-750 RPM at idle. Verify high Rpm.
- Y **1988 Pontiac Quad 4:** Non-contact non-antenna type placed just below and in front of the master cylinder on drivers side of the engine.
- Y **1992 Pontiac Quad 4:** Red contact lead clipped to purple wire going into the valve cover between the master cylinder and the valve cover.
- Y **1995 Toyota Camry Double Overhead Cam V-6:** Loop the Worldwide provided green wire around the drivers side front fuel injector wire which is located just under the black cover (does not require cover removal) and verify high and low RPM.
- Y **1992 Volvo 6Cyl.** Red contact lead open and held in place on the rear of the valve cover near the firewall. Set analyzer on conventional and four-cycle.
- Y **1992 Volvo 6Cyl.** Non-contact non-antenna type pickup placed on the cowl directly in front of the drivers side windshield wiper blade assembly. Set sensitivity on $\frac{3}{4}$ and four-cycle.
- Y **1994 Mitsubishi 6 Cyl.** Non-contact non-antenna type pickup placed on top of the battery upside down with the wire pointed towards the firewall. The sensitivity switch on the box was set at its lowest position (pulled all the way back towards the wire side) and the range and sensitivity was adjusted at the analyzer.
- Y **1989 PONTIAC Quad Four** Non-contact non-antenna type pick-up placed on the dash visor directly above the tachometer. The wire coming out of

the box should be pointed out the drivers window and the box sensitivity switch was set to the middle position. On screen range and sensitivity was set at the minimum levels.

Y 1992 Pontiac Quad Four- Red contact lead clipped on pink wire with black tracer using the green wire loop. This wire is located in the harness that goes under engine cover between the brake booster and valve cover.

Please be advised that these are just suggested methods and may not work on every vehicle. These methods have been used to obtain complete tests at the emissions lab. We will continue to update this list as new information is collected.

If you or any of your fellow techs come across a great method of getting a tachometer signal please call the emissions lab or give it to the emissions tech on his next visit. Who knows you may benefit from a tip yourself.

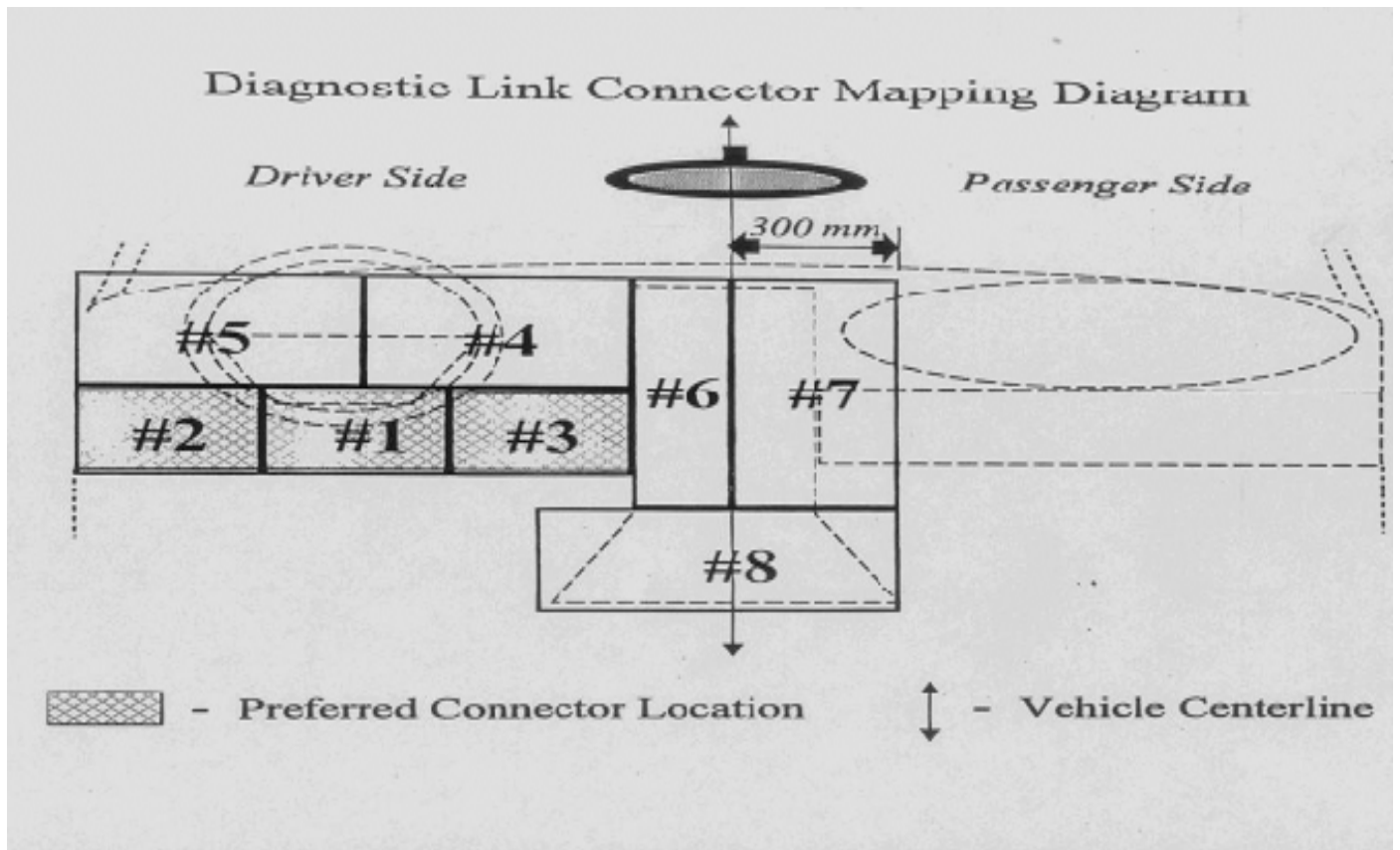



**State of Nevada
Department of Motor Vehicles
Vehicle Inspection Report**



OVERALL TEST RESULT: REJECTED

DUPLICATE

VEHICLE INFORMATION

Year: 1998	Cylinders: 6	County: WASHOE
Make: TOYOTA	GVWR Range: LIGHT DUTY < 8500	Zip: 89509
Model: TACOMA XTRACAB	Fuel: GASOLINE	Odometer: 101338
License Plate Number: 420NJK	Motor Home: NO	Inspection Type: INITIAL
VIN: 4TAVN52N5WZ073152		

AREAS OF EMISSION TEST REJECTION

Test Parameter	Result	Additional Information if available
OBD CATALYST	N	NOT COMPLETED
OBD EVAP	N	NOT COMPLETED
OXY SNSR	N	NOT COMPLETED
OXY SNSR HEAT	N	NOT COMPLETED
OBD EXHST GAS	N	NOT COMPLETED

STATION INFORMATION

TEST INFORMATION

Station Number: E0045249	Test Date: 07/28/2007 09:06:54
Analyzer Number: W1052	DMV ID: 312
Inspector Number: 10045942	Station Test Fee: \$24.00
	Total Fee: \$24.00

Test results have been forwarded electronically to the Department of Motor Vehicles. Fact sheets explaining requirements for vehicles rejected from emission testing are available from this emission station.



State of Nevada
Department of Motor Vehicles
Vehicle Inspection Report



OVERALL TEST RESULT: FAILED

DUPLICATE

VEHICLE INFORMATION

Year: 1989	Cylinders: 8	County: WASHOE
Make: LINCOLN	GVWR Range: LIGHT DUTY < 8500	Zip: 89523
Model: 9Y89	Fuel: GASOLINE	Odometer: 54599
License Plate Number: SMOGY	Motor Home: NO	Inspection Type: INITIAL
VIN: 8Y89A850019		

AREAS OF EMISSION TEST FAILURE

Test Parameter	Result	Additional Information if available
IDLE SPEED CO	8.50%	GREATER THAN 4.00%
HIGH SPEED CO	7.00%	GREATER THAN 4.00%
IDLE SPEED HC	1248	GREATER THAN 800 PARTS PER MILLION

STATION INFORMATION

Station Number: E0045249	Test Date: 07/27/2007 17:42:13
Analyzer Number: W1052	DMV ID: 301
Inspector Number: 10045942	VIR Number: G584
	Station Test Fee: \$24.00
	VIR Fee: \$6.00
	Total Fee: \$30.00

Test results have been forwarded electronically to the Department of Motor Vehicles. Fact sheets explaining requirements for failing vehicles are available from this emission station.

What to do if your vehicle has failed the emissions test...

First and foremost, read this document! It contains valuable information on how to proceed with vehicle repairs after a failed emission inspection.

- Repairs, other than Washoe County self-repairs, must be made at a State of Nevada DMV Authorized Station (2G Station).
- To obtain a list of State of Nevada DMV Authorized Stations (2G Station list)
 - **ASK** the Emission Inspector that just tested the vehicle for a State of Nevada DMV Authorized Emission Station list (2G Station list) or
 - **CONTACT** the State of Nevada DMV Emission Control Lab in your area or you may retrieve the list from the web:
 - **Las Vegas** (702) 486-4981 – 2701 East Sahara Ave, Las Vegas, NV 89104
 - **Reno** (775) 684-3580 – 305 Galletti Way, Reno, NV 89512
 - **Web** <http://www.dmvnv.com/emissions/2g.asp>

A vehicle is not eligible for a waiver if:

- It was repaired at an automotive repair facility that is **NOT** a State of Nevada DMV Authorized Station (2G Station).
- It emits visible smoke.
- The repairs were done to emission systems that were operating to manufacturer specifications.
- The repairs performed were on the catalytic converter, fuel inlet restrictor, air injection system, EGR system or for tampered, missing, or required emission devices.
- It is under manufacturer's warranty.
- The repairs done to and/or parts installed in your vehicle were not directly related to the emission failure.
- The minimum repair expenditures were not met.

Clark County Emission Test Waiver Requirements:

- Repairs must be done at a State of Nevada DMV Authorized Station (2G Station).
 - Must present proof that a minimum of \$450 was spent on labor and/or parts directly related to the emission failure, excluding the cost of the emission tests.
- **The cost for self-repairs and emission tests will not be considered towards an emission test waiver.**

Washoe County Emission Test Waiver Requirements:

- For repairs done at a State of Nevada DMV Emission Station (2G Station):
 - Must present proof that the minimum of \$200 spent on labor and/or parts directly related to the emission failure excluding the cost of the emission tests.
- For self-repairs:
 - Must present proof that a minimum of at least \$200 was spent on installed parts purchased within 14 days after the initial failing emission test.
 - Installed parts must be directly related to the emission test failure.
 - **The cost of labor and emission tests will not be considered towards an emission test waiver.**

To apply for an emission test waiver, you must go to the Emission Control Lab in your area and present:

- The vehicle that failed the emission test.
- If repaired at an automotive repair facility, receipts that document repairs were done at a State of Nevada DMV Authorized Station (2G Station).
- If self-repaired, dated receipts that document the cost of the repair parts that directly relate to the emission test failure.
- Two failed emission tests:
 - The failed emission test that occurred before any repairs are made to the vehicle and
 - The failed emission test, after repairs were made to the vehicle.

VEHICLES "REJECTED" FROM EMISSION TESTING

All HEAVY DUTY & PRE 1996 LIGHT DUTY VEHICLES

Heavy Duty and Pre 1996 Light Duty vehicles are "rejected" from emission tests for two main reasons:

- (1) The vehicle's engine speed or RPM (revolutions per minute) at idle is too high for the emission analyzer to conduct a test.
- (2) The dilution of the vehicle's exhaust gases is outside the acceptable range allowed by current law.

VEHICLES REJECTED FROM TESTING

If your vehicle has been rejected from emission testing due to an RPM or exhaust dilution issue, the DMV recommends that you take your vehicle to an authorized (2G) repair technician. Please call your nearest DMV Emission Test Lab if you have questions about your test results.

OBD II LIGHT- DUTY VEHICLES (1996 AND NEWER)

OBD II vehicles are primarily "rejected" from emission tests because:

- (1) The data link connector is not accessible, damaged, or aftermarket wiring is present the vehicle is "rejected" from testing. For example, if an accessory such as a CB radio is installed in front of the data link connector the vehicle is rejected from testing.
- (2) The trouble codes have been recently cleared or the battery has been disconnected or replaced.
- (3) Too many OBD II monitors are unset.

Emission stations can charge a fee for vehicles inspected and found to have problems that reject them from the emission test. There is no charge for a Vehicle Inspection Report in this situation.

Any vehicle "rejected" from testing because of unset monitors must be driven in order to meet the necessary "drive cycle" requirements for the monitors that are reporting as "not ready." Most vehicles will set their monitors within one week of normal driving. There are a limited number of vehicles equipped with monitors that will not set unless manufacturer specific drive cycles are performed by qualified emission repair technicians. Please contact the Department of Motor Vehicles Emission Test Lab nearest you to obtain information for hard to test vehicles.

CLEARING OF TROUBLE CODES

Clearing trouble codes and/or turning off the "check engine" light without performing the necessary repairs will not allow the vehicle to pass an emission test. When trouble codes are cleared, all monitors will reset to "Not Ready" and the vehicle cannot be emission tested until all drive cycles are completed.

The "check engine" light will typically come back on if the repairs have not been made because the original problem will re-appear and be detected by the monitor during the drive cycle.

(2G) REPAIR TECHNICIANS

An authorized (2G) repair technician can diagnose and repair vehicles with emission system problems. A list of qualified test and repair (2G) facilities can be obtained from any emissions test station or the Department of Motor Vehicles Emission Test Lab.

FOR FURTHER QUESTIONS

Please contact the Department of Motor Vehicles Emission Control Test Lab nearest you. The locations of the emission control offices in Reno and Las Vegas are listed below:

Las Vegas

DMV Emission Test Lab
2701 East Sahara Avenue
Las Vegas, Nevada 89104
(702) 486-4981

Reno

DMV Emission Test Lab
305 Galletti Way
Reno, Nevada 89512
(775) 684-3580





State of Nevada
Department of Motor Vehicles
Vehicle Inspection Report



OVERALL TEST RESULT: FAILED

DUPLICATE



1G1JC1241S7153541

VEHICLE INFORMATION

Year: 1995	Cylinders: 4	County: CLARK
Make: CHEVROLET	GVWR Range: LIGHT DUTY < 8500	Zip: 89122
Model: CAVALIER	Fuel: GASOLINE	Odometer: 131211
License Plate Number:	Motor Home: NO	Inspection Type: INITIAL
VIN: 1G1JC1241S7153541		

AREAS OF EMISSION TEST FAILURE

Test Parameter	Result	Additional Information if available
FUEL CAP TAMPER	EX-PASS	FAIL 3/15/2008 - MAJ XXXX [Signature]

STATION INFORMATION

Station Number: E0000739
 Analyzer Number: W1102
 Inspector Number: I0047724

TEST INFORMATION

Test Date: 03/14/2008 08:19:44
 DMV ID: 256742
 VIR Number: G234886
 Station Test Fee: \$19.00
 VIR Fee: \$6.00
 Total Fee: \$25.00

Test results have been forwarded electronically to the Department of Motor Vehicles. Fact sheets explaining requirements for failing vehicles are available from this emission station.



State of Nevada
Department of Motor Vehicles
Vehicle Inspection Report



OVERALL TEST RESULT: PASS



1N6ED27Y2YC305

VEHICLE INFORMATION	TEST INFORMATION	STATION INFORMATION
Year: 2000	Test Date: 03/18/2008 12:59:40	Station Number: E0046061
Make: NISSAN	DMV ID: 268561	Analyzer Number: W1016
Model: FRONTIER XE/SE	VIR Number: G255733	Inspector Number: I0046452
License Plate Number: KJUPEPE	Station Test Fee: \$19.99	
VIN: 1N6ED27Y2YC305	VIR Fee: \$6.00	
Odometer: 70092	Total Fee: \$25.99	

Test results have been forwarded electronically to the Department of Motor Vehicles.
Thank you for helping keep our air clean by having your vehicle emission tested.

This Emission Test is valid for registration purposes for 90 days upon date of issuance.



***A Tri-mobile classified as a motorcycle pursuant to the Code of Federal Regulation (CFR) 40 CFR § 86.402-78 or 86.402-98. A Tri-mobile, model year 1997 or older is considered a motorcycle if it weighs less than 1,500 pounds. A Tri-mobile, model year 1998 or newer is considered a motorcycle if it weighs less than 1,750 pounds.**

(Refer to Assembly Bill 414 2009 Legislative Session)



State of Nevada
Department of Motor Vehicles
Emissions Exception Vehicle Report



EXCEPTION VEHICLE REPORT

Auditor: LOUIS DOMINGUEZ	Date / Time: 02/25/2008 12:43:50
Vehicle Type: EMISSION CONTROL LABEL	County: CLARK

VEHICLE INFORMATION

Vin: WDB1260221A160234	Year: 1985
Make: MERCEDES-BENZ	Weight Range: Light Duty Gas

ENGINE INFORMATION

Serial #: R1100161901	Cylinders: 6
Make: MERCEDES-BENZ	Model: STRAIGHT SIX
Year: 1985	Displacement: 3.5

VEHICLE REGISTRATION INFORMATION

Year: 1985	Make: MERCEDES-BENZ	Model: 280SE
------------	---------------------	--------------

TEST VEHICLE FOR THE FOLLOWING:

1968-1980 Model Yr 1981-1995 LDG Model Yr 1996 or newer HDG Model Yr	1996 or newer Model Yr	Light Duty Diesel
Air Injection: Yes	DLC: No	Catalyst LDD: No
Catalyst: Yes	MIL: No	EGR System: No
EGR: Yes		Crankcase Vent System: No
Fuel Inlet Restrictor: Yes		Fuel Cap LDD: No
Fuel Cap: Yes		MFG Advt Rated HP: 0
		Dynamometer Speed:
		Dynamometer HP: 0

EMISSION TEST VEHICLE AS: TSI-LD