

**ADOPTED REGULATION OF THE  
STATE ENVIRONMENTAL COMMISSION**

**LCB File No. R194-07**

Effective August 26, 2008

EXPLANATION – Matter in *italics* is new; matter in brackets ~~[omitted material]~~ is material to be omitted.

AUTHORITY: §§1-41, 46, 50-52, 58, 61-66, 69-83 and 89-92, NRS 445A.425; §§42-44, NRS 445A.425 and 445A.490; §45, NRS 445A.425, 445A.445, 445A.490 and 445A.500; §47, NRS 445A.425 and 445A.500; §§48 and 57, NRS 445A.425, 445A.490 and 445A.500; §49, NRS 445A.425, 445A.445, 445A.475, 445A.480, 445A.500, 445A.505 and 445A.515; §53, NRS 445A.425, 445A.445 and 445A.515; §54, NRS 445A.425, 445A.430, 445A.475 and 445A.500; §55, NRS 445A.425 and 445A.475; §56, NRS 445A.425, 445A.500 and 445A.515; §59, NRS 445A.425, 445A.445 and 445A.505; §§60 and 85, NRS 445A.425 and 445A.450; §§67 and 68, NRS 445A.425 and 445A.480; §84, NRS 445A.425 and 445A.480; §86, NRS 445A.425 and 445A.515; §87, NRS 445A.425 and 445A.430; §88, NRS 445A.425 and 445A.445.

A REGULATION relating to pollution; providing for the permitting of on-site domestic sewage disposal systems other than those intended for a single-family dwelling by the Division of Environmental Protection of the State Department of Conservation and Natural Resources; and providing other matters properly relating thereto.

**Section 1.** NAC 211.550 is hereby amended to read as follows:

211.550 All sewage and liquid waste matter must be disposed of into a public system of sewerage, if available. If public sewerage is not available, disposal must be made into a private system of sewage disposal which is designed, constructed and operated in accordance with the requirements of the health authority ~~[ ]~~ *or, if the system is an on-site sewage disposal system, the Division of Environmental Protection of the State Department of Conservation and Natural Resources or other administrative authority pursuant to sections 3 to 89, inclusive, of this regulation.* If public sewerage becomes available, connections must be made thereto, the

institution's use of the private system *or on-site sewage disposal system* must be discontinued and the private system *or on-site sewage disposal system* must be properly abandoned.

*Procedures for abandonment of an on-site sewage disposal system are provided by the Division of Environmental Protection of the State Department of Conservation and Natural Resources in fact sheet "WTS-20: Abandonment of Sewerage Facilities," which is available from the Division and at the Internet address <http://ndep.nv.gov/bwpc/fact01.htm>.*

**Sec. 2.** Chapter 445A of NAC is hereby amended by adding thereto the provisions set forth as sections 3 to 89, inclusive, of this regulation.

**Sec. 3.** *As used in sections 3 to 89, inclusive, of this regulation, unless the context otherwise requires, the words and terms defined in sections 4 to 41, inclusive, of this regulation have the meanings ascribed to them in those sections.*

**Sec. 4.** *"Administrative authority" means an officer, board, department or agency of a county, city or other political subdivision of this State that has entered into an agreement with the Division to administer and enforce sections 3 to 89, inclusive, of this regulation governing on-site sewage disposal systems within the jurisdiction of the county, city or other political subdivision.*

**Sec. 5.** *"Administrator" means the Administrator of the Division.*

**Sec. 6.** *"Advanced wastewater treatment unit" means a treatment unit that treats domestic sewage to discharge levels that exceed conventional septic tank effluent. The term includes, without limitation, a system using an aerobic wastewater treatment unit, a denitrification system or a recirculation system.*

Sec. 7. *“Aerobic wastewater treatment unit” means a treatment unit which adds oxygen to sewage and is designed to provide an additional level of sewage treatment before the disposal of sewage.*

Sec. 8. *“Alternative system” means any alternative treatment unit, alternative effluent absorption system or combination of both that is approved by the Division or other administrative authority for use as or in an on-site sewage disposal system.*

Sec. 9. *“Biochemical oxygen demand” means a measure, set forth in milligrams per liter or parts per million, of the amount of oxygen required by any bacteria or other microorganisms to oxidize any organic matter present in a water sample over a period of 5 days.*

Sec. 10. *“Capping fill trench” means an effluent absorption system for which the disposal pipe is at or near grade and the effective disposal trench sidewall is installed at least 12 inches into the natural soil and below a soil cap.*

Sec. 11. *“Certificate of completion” means a statement issued in writing by a design engineer that certifies to the Division or other administrative authority that an on-site sewage disposal system is constructed in accordance with the plans and specifications approved by the Division or other administrative authority for the on-site sewage disposal system.*

Sec. 12. *“Cesspool” means a covered excavation in the ground which receives the discharge of domestic sewage or other organic wastes from a drainage system which is designed to retain organic matter and solids while permitting liquids to seep through the bottom and sides.*

Sec. 13. 1. *“Cluster system” means a sewage system:*

*(a) Which serves a group of residences or other occupied buildings that discharges sewage into an individual septic tank on each property or into a common septic tank which is connected to a central effluent absorption system; and*

*(b) For which the Department or other administrative authority determines there is no identifiable and responsible ownership of the sewage system and no enforcement authority among the users of the system.*

*2. The term does not include a mobile home park.*

*3. As used in this section, “mobile home park” has the meaning ascribed to “manufactured home park” in NRS 118B.017.*

**Sec. 14.** *“Commercial facility” means any structure, building, group of structures or buildings, or mobile home park, or any portion thereof, other than a single-family dwelling.*

**Sec. 15.** *“Department” means the State Department of Conservation and Natural Resources.*

**Sec. 16.** *“Design engineer” means a person who is licensed by the State Board of Professional Engineers and Land Surveyors to practice professional engineering in this State.*

**Sec. 17.** *“Director” means the Director of the Department or his designee.*

**Sec. 18.** *“Division” means the Division of Environmental Protection of the Department.*

**Sec. 19.** *“Domestic sewage” means any liquid and water-borne waste that is derived from the ordinary living process and is of such a character as to permit its satisfactory disposal into a public sewer or an on-site sewage disposal system without special treatment. The term does not include industrial or hazardous waste.*

**Sec. 20.** *“Drain media” means any clean washed gravel, clean crushed rock or other type of natural or synthetic aggregate, including, without limitation, chipped tires, which is*

*approved by the Administrator for use in the distribution and treatment of effluent after determining that it is sufficiently durable and inert so that it maintains its integrity and does not collapse or disintegrate over time and is not detrimental to the performance of the on-site sewage disposal system.*

**Sec. 21.** *“Effluent absorption system” means any sewage treatment system that distributes and treats effluent for subsurface disposal.*

**Sec. 22.** *“Failing system” means any sewage treatment system which discharges untreated or incompletely treated sewage or septic tank effluent directly or indirectly on the surface of the ground or into any waters of the State.*

**Sec. 23.** *“Filter media” means sand or other similar material used in a sand filter.*

**Sec. 24.** *“General permit” means a permit to operate an on-site sewage disposal system that:*

- 1. Handles 15,000 gallons of flow per day or less;*
- 2. Receives only domestic sewage; and*
- 3. Uses subsurface disposal.*

**Sec. 25.** *“Individual permit” means a permit to operate an on-site sewage disposal system that:*

- 1. Handles more than 15,000 gallons of flow per day;*
- 2. Receives flows other than domestic sewage;*
- 3. Uses surface disposal; or*
- 4. Serves as a cluster system.*

Sec. 26. *“Industrial waste” means any liquid, gaseous, radioactive or solid waste substance, or combination thereof, resulting from any process of industry, manufacturing, trade or business or from the development or recovery of any natural resource.*

Sec. 27. *“Long-term acceptance rate” means the volume of wastewater that can be applied to a square foot of soil each day, over an indefinite period, such that the wastewater is properly treated and the effluent is absorbed. The rate is dependent upon the most restrictive percolation rate and the texture of the soil to a depth of 4 feet below the proposed bottom of the absorption area.*

Sec. 28. *“Nitrogen management area” means an area that has been identified by the Division with levels of nitrogen that are at or approaching 5 milligrams per liter measured as total nitrogen in the groundwater or surface water.*

Sec. 29. *“Nitrogen removal wastewater treatment unit” means a treatment unit that significantly reduces the total nitrogen level of effluent through biological denitrification, chemical reduction or ion exchange.*

Sec. 30. *“Nitrogen restricted area” means an area that has been identified by the Division as having levels of nitrogen that are at or approaching 10 milligrams per liter measured as total nitrogen in the groundwater or surface water.*

Sec. 31. *“On-site sewage disposal system” means any existing or proposed on-site system for the treatment and disposal of domestic sewage, including, without limitation, a standard subsurface, alternative or experimental sewage disposal system that may include a treatment unit and an effluent absorption system. The term includes a Class V well as set forth in subsection 10 of NAC 445A.849. The term does not include an individual sewage disposal*

*system as defined in NAC 444.764, a package plant for sewage treatment as defined in NRS 445A.380, or a system designed to treat and dispose of industrial waste.*

**Sec. 32.** *“Percolation test” means a procedure to determine the relatively constant rate, calculated in minutes per inch, at which clear water maintained at a constant depth seeps out of a standard-sized test hole that has been previously saturated.*

**Sec. 33.** *“Person” means any natural person, corporation, association, firm, partnership, joint-stock company, public or municipal corporation, political subdivision, the State or any agency thereof, or the Federal Government and any agency thereof.*

**Sec. 34.** *“Pressure distribution system” means any effluent absorption system designed to uniformly distribute septic tank or other treatment unit effluent under pressure into an effluent absorption system.*

**Sec. 35.** *“Projected daily sewage flow” means the peak quantity of sewage a facility is estimated to produce on a daily basis and upon which the sizing and design of the on-site sewage disposal system is based.*

**Sec. 36.** *“Sand filter” means a portion of an effluent absorption system with 2 feet or more of sand or any other filter media designed to chemically and biologically process septic tank or other treatment unit effluent from a pressure distribution system operated on an intermittent basis.*

**Sec. 37.** *“Sand filter system” means an alternative effluent absorption system that uses:*

- 1. A dosing system with an effluent pump and controls or a dosing siphon, piping and fittings; and*
- 2. An absorption system which includes a sand filter.*

Sec. 38. *“Total suspended solids” means the total amount of filterable solids in a water sample, measured in milligrams per liter.*

Sec. 39. *“Treatment unit” means a septic tank or other system designed to treat sewage before its release into an effluent absorption system.*

Sec. 40. *“Vector attraction” means the natural attraction of living organisms, including, without limitation, insects, rodents and birds, that are capable of transmitting a pathogen from one organism to another, to sewage, effluent or other by-products of the sewage disposal process.*

Sec. 41. *“Waters of the State” has the meaning ascribed to it in NRS 445A.415.*

Sec. 42. 1. *The purpose of sections 3 to 89, inclusive, of this regulation is to prescribe the requirements for on-site sewage disposal systems for the protection of the public health, safety and welfare of the people of the State of Nevada.*

2. *The provisions set forth in sections 3 to 89, inclusive, of this regulation are intended to:*

*(a) Protect the public health and safety;*

*(b) Prevent contamination of any drinking water supply, aquifer or other waters of the State;*

*(c) Prevent odors and vector attraction; and*

*(d) Provide guidance to owners and operators of on-site sewage disposal systems and to design engineers.*

Sec. 43. 1. *An administrative authority that enters into an agreement with the Division to regulate on-site sewage disposal systems within the jurisdiction of the administrative authority may develop its own regulations for such systems.*



*2. Regulations developed by an administrative authority pursuant to subsection 1 must be at least as stringent as sections 3 to 89, inclusive, of this regulation.*

*3. An administrative authority that regulates on-site sewage disposal systems pursuant to subsection 1 shall provide an annual report to the Division listing all on-site sewage disposal systems operating in the jurisdiction of the administrative authority.*

**Sec. 44.** *The Division, by review and approval of the plans and specifications for an on-site sewage disposal system and the issuance of a permit pursuant to sections 3 to 89, inclusive, of this regulation, assumes no responsibility for the successful operation of that system. Ensuring that such a system will operate satisfactorily is the responsibility of the design engineer and the person constructing and operating the system. Any permit issued pursuant to sections 3 to 89, inclusive, of this regulation is a revocable privilege, and the holder of such a permit does not acquire thereby any vested right.*

**Sec. 45.** *1. A permit must not be issued for the construction or operation of an on-site sewage disposal system that is likely to pollute any waters of the State or create a public health hazard. If, in the judgment of the Division or other administrative authority, the minimum standards set forth in sections 3 to 89, inclusive, of this regulation will not adequately protect the waters of the State or the public health due to circumstances unique to the site or the intended use of the system, the Division or other administrative authority shall require an on-site sewage disposal system to meet additional requirements that will provide adequate protection. Such additional requirements may include, without limitation, increased setback, increased drain field size, additional treatment or use of an alternative system. The Division or other administrative authority shall deny the construction or operation of an on-site sewage disposal system if it is determined that the construction or operation of the system will impact*

*the waters of the State or is in an area where a moratorium on such systems has been established. The Division or other administrative authority shall provide an applicant with a written statement of the specific reasons for more stringent requirements or why a permit was denied under this subsection.*

*2. The minimum land area required for an on-site sewage disposal system is 43.5 square feet per gallon of projected daily sewage flow per day, which is the equivalent of 1,000 gallons of flow per acre per day, and must include a backup area equal to the size of the effluent absorption area which must be set aside for future use. The use of an advanced wastewater treatment unit may allow for a reduction that is not more than 25 percent in land area, if the design engineer can demonstrate to the satisfaction of the Division or other administrative authority that the on-site sewage disposal system will not adversely impact the local groundwater or surface water.*

*3. An on-site sewage disposal system with projected daily sewage flow greater than:*

*(a) Fifteen thousand gallons per day, or which receives flows other than domestic sewage, must obtain an individual permit from the Division or other administrative authority.*

*(b) Five thousand gallons per day may be required by the Division or other administrative authority to obtain a groundwater mounding analysis. If required by the Division or other administrative authority, the design engineer shall submit sufficient site-specific data which predicts both the height of the water-table mound that will develop beneath the field and the rate of lateral and vertical flow away from the absorption area. The site will be deemed unsuitable if the data predicts that the water-table mound that will develop beneath the site cannot be maintained 4 feet or more below the bottom of the absorption area or if it is determined that effluent is likely to become exposed onto the ground surface.*

4. *All sewage within an on-site sewage disposal system must be treated and dispersed in a manner approved in accordance with sections 3 to 89, inclusive, of this regulation, and cesspools are prohibited.*

5. *A person shall not discharge untreated or partially treated wastewater or septic tank effluent directly or indirectly onto the ground surface or into a deep pit, mine shaft, abandoned well or other waters of the State. Such discharge constitutes a public health hazard and is prohibited.*

6. *A person shall not discharge into any on-site sewage disposal system cooling water, air-conditioning water, water softener brine, swimming pool or hot tub water, groundwater, oil, hazardous materials, roof drainage or other aqueous or nonaqueous substances that are detrimental to the performance of the system or to groundwater. Commercial kitchens must provide a grease interceptor, approved by the appropriate local health authority, before discharge to the septic tank or other treatment unit. Laundromats must provide a lint interceptor before discharge into a septic tank or other treatment unit.*

7. *A person shall not connect a commercial facility to an on-site sewage disposal system if the additional flow would result in a greater projected daily sewage flow than that allowed under the permit for the system, unless expressly allowed by the Division or other administrative authority.*

8. *Each on-site sewage disposal system must have adequate capacity to properly treat and disperse the maximum projected daily sewage flow. The projected daily sewage flow must be determined from the table set forth in section 65 of this regulation or from another source specified by the Division or other administrative authority.*

9. *The owner of an on-site sewage disposal system shall operate and maintain the system in compliance with all permit conditions and applicable requirements set forth in sections 3 to 89, inclusive, of this regulation and shall not create a public health or safety hazard or pollute the waters of the State.*

10. *Any aspect of design, construction, operation or maintenance of an on-site sewage disposal system not addressed in sections 3 to 89, inclusive, of this regulation must meet the most restrictive requirements in the current publication of the Uniform Plumbing Code, adopted by reference in section 46 of this regulation, and any guidelines established by the Division.*

11. *All plumbing fixtures in commercial facilities and other structures from which sewage is or may be discharged must be connected to and discharge into an approved area-wide sewerage system or a permitted on-site sewage disposal system that is not a failing system.*

**Sec. 46.** *The following publications are hereby adopted by reference:*

1. *The Uniform Plumbing Code, 2006 edition, published by the International Association of Plumbing and Mechanical Officials. A copy of this publication is available by mail from the International Association of Plumbing and Mechanical Officials, 20001 Walnut Drive South, Walnut, California 91789-2825, by telephone at (800) 854-2766 or at the Internet address <http://www.iapmostore.org/>, for the price of \$93.*

2. *Design Manual: On-site Wastewater Treatment and Disposal Systems, published by the United States Environmental Protection Agency, October 1980, document number EPA 625/1-80-012, which is available free of charge at the Internet address <http://www.epa.gov/ordntrnt/ORD/NRMRL/pubs/625180012/625180012.htm>.*

3. *The On-site Wastewater Treatment Systems Manual, published by the United States Environmental Protection Agency, February 2002, document number EPA 625/R-00/008, which is available free of charge at the Internet address <http://www.epa.gov/ordntrnt/ORD/NRMRL/pubs/625r00008/html/html/625R00008.htm>.*

**Sec. 47.** *Except as otherwise provided in this section, the Division or other administrative authority may grant an exemption from any provision of sections 3 to 89, inclusive, of this regulation to the holder of a permit to operate an on-site sewage disposal system if the exemption:*

1. *Is justified in writing and is signed and stamped by a design engineer;*
2. *Involves an advance in technology, an improvement in materials or an alternative method of construction, operation or maintenance that, as determined by the Division or other administrative authority, is not detrimental to the public health and safety; and*
3. *Provides for a level of protection for the environment that, as determined by the Division or other administrative authority, is similar to or greater than that provided by sections 3 to 89, inclusive, of this regulation.*

**Sec. 48.** 1. *Whenever the Division or other administrative authority determines that the construction of an on-site sewage disposal system should be limited or prohibited in a specific area for reasons including, without limitation, high groundwater, shallow bedrock, extreme slope, or designation as a nitrogen management area or a nitrogen restricted area, the Division or other administrative authority shall issue an order limiting or prohibiting that construction. In addition, the Division or other administrative authority shall not permit the construction or operation of an on-site sewage disposal system where an area-wide*

*management plan, prepared pursuant to section 208 of the Clean Water Act, 33 U.S.C. § 1288, prohibits such a system.*

*2. The Division is responsible for the designating of nitrogen management areas. New or altered nitrogen management area boundaries will be delineated only after the Division and the appropriate local government have met and concurred on the boundary description.*

*3. If the Division designates an area as a nitrogen management area:*

*(a) Standard septic tank and absorption area systems will not be permitted by the Division, and any new construction of an on-site sewage disposal system will require installation of a nitrogen removal treatment system; and*

*(b) The Division shall notify the appropriate local governing agency in writing of the designation of the nitrogen management area, the consequences of such a designation, the impact such a designation will have on future subdivision approval and the fact that continued elevation of the level of nitrates in groundwater in the area may result in a designation as a nitrogen restricted area.*

*4. Before the Division may designate an area as a nitrogen restricted area, the Division shall conduct a public hearing, for which 30 days' notice must be given to interested parties in the affected area.*

*5. If the Division designates an area as a nitrogen restricted area:*

*(a) The Division shall issue an order prohibiting on-site sewage disposal systems pursuant to subsection 1; and*

*(b) The Division shall not approve a subdivision in the nitrogen restricted area, pursuant to NAC 278.420, if the proposed method of sewage disposal is either an on-site sewage disposal system or an individual sewage disposal system as defined in NAC 444.764.*

**Sec. 49. 1.** *A letter of approval must be obtained from the Division or other administrative authority to construct, alter or expand an on-site sewage disposal system. Construction must not commence until the design specifications have been approved in writing by the Division or other administrative authority. A request for a letter of approval is also a request for the on-site sewage disposal system to be included under a general or individual permit, as applicable. Coverage under a general or individual permit must not begin until the design engineer submits the certificate of completion and the Division or other administrative authority grants the permit.*

*2. A request for a letter of approval to construct, alter or expand an on-site sewage disposal system must outline the scope of the proposed construction and provide an analysis of the capability of the disposal area to adequately treat and dispose of the proposed sewage quantities from the system. The request must include:*

- (a) The name, address and current telephone number of the applicant;*
- (b) The legal description of the property, including, without limitation, the lot and block number, township, range section and assessor's parcel number;*
- (c) An engineering report bearing the signature and original stamp of a design engineer;*
- (d) A plot plan bearing the signature and original stamp of a design engineer; and*
- (e) Design specifications for the on-site sewage disposal system bearing the signature and original stamp of a design engineer.*

**Sec. 50. 1.** *The engineering report required pursuant to section 49 of this regulation must include, without limitation, a soils analysis performed by a qualified person approved by the Division or other administrative authority, including, without limitation, a design engineer, a soils scientist or a geologist. The soils analysis must include, without limitation:*

*(a) Data from a percolation test pursuant to section 71 of this regulation, from a minimum of two test holes in the area of the proposed effluent absorption system, unless an alternative investigation of soil characteristics pursuant to section 72 of this regulation is used. If an alternative investigation of soil characteristics is performed, the results of that investigation must be included in the soils analysis.*

*(b) Soil logs from at least one test pit excavated to a minimum depth of 5 feet below the bottom of the proposed absorption system. The soil logs must describe the soil in accordance with sections 28 through 30, Figure 29-1, Table 29-1 and Appendix A of Design Manual: On-site Wastewater Treatment and Disposal Systems, as adopted by reference in section 46 of this regulation. The soil logs must include notations relating to impervious barriers, bedrock, fractures, areas of open solution, clay, caliche or other limiting factors. The depth to the seasonal high groundwater, as observed as the surface of free water or as indicated by mottling or historical documentation, must also be included in the soil logs.*

*(c) Verification by the design engineer, soils scientist or geologist of the depth of the high groundwater and bedrock, areas susceptible to flooding, the ground slope and the results of percolation tests, including, without limitation, a morphological study of soil conditions with particular reference to soil color and sequence of horizons. In addition:*

*(1) If the natural soil condition has been altered by filling or other attempts to improve wet areas, the Division or other administrative authority may require the verification by the design engineer, soils scientist or geologist to include observation of high groundwater levels under saturated soil conditions.*

*(2) If the natural soil condition has been altered by filling or other attempts to improve the percolation rate of the soil, the Division or other administrative authority may require the*



*verification by the design engineer, soils scientist or geologist to include a determination of whether the fill material is suitable for an on-site sewage disposal system.*

*(d) The long-term acceptance rate of the soil, as referenced in the table set forth in section 74 of this regulation.*

*(e) If required by the Division or other administrative authority pursuant to paragraph (b) of subsection 3 of section 45 of this regulation, a groundwater mounding analysis.*

*2. The Division or other administrative authority may require the design engineer to include in the engineering report a nitrogen balance to demonstrate that the effluent will not cause any waters of the State to exceed the maximum contaminant level of nitrate, and groundwater samples from the installed monitoring wells must be obtained before initiation of operation of the on-site sewage disposal system.*

*3. The engineering report may include any other data determined by the design engineer to be relevant to the design specifications of the proposed on-site sewage disposal system.*

**Sec. 51.** *The plot plan required pursuant to section 49 of this regulation must include:*

*1. The title and date of the plot plan and the scale to which the plot plan is drawn, with the direction north clearly indicated.*

*2. A map of the area in which the on-site sewage disposal system will be located, indicating the location of roads and streets and the dimensions of the lot.*

*3. The location of and distance to wells and sewage systems, if any, on surrounding lots. If surrounding lots are vacant, the plot plan must so indicate.*

*4. The distance to any watercourse that is within 500 feet of the proposed on-site sewage disposal system, including, without limitation, any pond, lagoon or stream. If there are no watercourses, the plot plan must so indicate.*

5. *The location of each percolation test hole, excavated pit or boring test hole.*
  6. *The location and depth of each proposed or actual well on the property, including the depth of casing and surface grout seal. Logs for all existing wells on the property must be submitted as part of the plot plan.*
  7. *Each component of the on-site sewage disposal system, which must be marked and located at specified distances in units of feet.*
  8. *The distance to any public or private sewage collection lines located within 200 feet of the site. If there are no public or private sewage collection lines within 200 feet of the site, the plot plan must so indicate.*
  9. *The maximum slope across the proposed effluent absorption system area.*
  10. *The location of any water supply lines, building sewer lines and other underground utilities.*
  11. *The location and dimensions of any structures, paved areas, driveways, trees and patios.*
  12. *The location of the water source to be used by the on-site sewage disposal system, including, without limitation, a well or other source.*
  13. *The location and dimensions of the proposed backup effluent absorption area.*
- Sec. 52. 1.** *The design specifications required pursuant to section 49 of this regulation must include evidence that the proposed design for the on-site sewage disposal system is prepared in accordance with sections 3 to 89, inclusive, of this regulation and any other design criteria justified by the design engineer.*

*2. The design specifications must be based on the information provided in the engineering report and the plot plan prepared pursuant to sections 50 and 51 of this regulation.*

*3. The design specifications must include, without limitation:*

*(a) A general statement as to the suitability of the site for the disposal of sewage and the advantages of the design proposed.*

*(b) A system design that meets the requirements for setbacks and cleanouts pursuant to sections 62 and 63 of this regulation.*

*(c) Specifications for a treatment system, including, without limitation, a septic tank or an aerobic wastewater treatment unit, designed pursuant to sections 64 to 68, inclusive, of this regulation.*

*(d) Specifications for an effluent absorption system, including, without limitation, an absorption trench system or chamber system, designed pursuant to sections 70 to 82, inclusive, of this regulation.*

*(e) A draft operations and maintenance manual prepared pursuant to section 85 of this regulation.*

**Sec. 53.** *1. The design engineer may provide to the Division or other administrative authority any information that demonstrates any new or innovative technologies, materials or designs for a proposed on-site sewage disposal system or a proposed component of such a system that achieves equal or greater performance than a system that meets the requirements of sections 3 to 89, inclusive, of this regulation. The Division or other administrative authority may require independent verification of any proposed new innovative technologies, materials or designs.*

*2. The Division or other administrative authority may approve the use of any technology, material or design specified in subsection 1 if the Division or other administrative authority determines that the proposed system or component will protect the public health and safety and the waters of the State as effectively as systems or components authorized in sections 3 to 89, inclusive, of this regulation.*

*3. The Division or other administrative authority shall deny a request for approval of any new or innovative technologies, materials or designs for a proposed on-site sewage disposal system or a proposed component of such a system:*

*(a) If the proposed system or component:*

*(1) Fails to achieve equal or better performance than specific systems or components authorized in sections 3 to 89, inclusive, of this regulation;*

*(2) Fails to address site or system conditions as satisfactorily as or more satisfactorily than specific systems or components authorized in sections 3 to 89, inclusive, of this regulation;*

*(3) Is insufficiently justified based upon the information provided by the design engineer; or*

*(4) Requires excessive review time, research or specialized expertise by the Division or other administrative authority to act on the request; or*

*(b) For any other cause specified by the Division or other administrative authority.*

**Sec. 54. 1.** *The design engineer shall inspect the construction of the proposed on-site sewage disposal system during critical phases of construction, including, without limitation, installation of the treatment unit, excavation of the absorption area and installation of the drain media or other effluent absorption system.*

2. *The design engineer shall issue a certificate of completion for the on-site sewage disposal system when he determines that the system complies with all applicable requirements of sections 3 to 89, inclusive, of this regulation and any additional conditions required by the Division or other administrative authority. The Division or other administrative authority may request that photographic documentation of the phases of construction be submitted together with the certificate of completion.*

3. *A permit must not be issued until the certificate of completion, bearing the original stamp and signature of the design engineer, and the appropriate fees, if any, required pursuant to section 87 of this regulation or by an administrative authority have been received by the Division or other administrative authority.*

**Sec. 55.** 1. *A permit issued by the Division or other administrative authority pursuant to sections 3 to 89, inclusive, of this regulation authorizes the holder of the permit to operate an on-site sewage disposal system. Except as otherwise provided in NRS 445A.495, a permit is valid until:*

*(a) The on-site sewage disposal system fails; or*

*(b) A public or community sewerage system is installed to service the area.*

2. *For the purposes of sections 3 to 89, inclusive, of this regulation, an on-site sewage disposal system shall be deemed to have failed if a condition or malfunction occurs in the system or in its operation that threatens the public health by inadequately treating sewage or by creating the potential for direct or indirect contact between sewage and the public, including, without limitation:*

*(a) Sewage on the surface of the ground;*

*(b) A backup of sewage into a structure;*

*(c) The leaking of sewage from a septic tank or other treatment unit;*

*(d) Contamination of groundwater or surface water by effluent; or*

*(e) Failure of the operator of the system to comply with the requirements of the permit, including, without limitation, causing levels of nitrogen in groundwater to leave the system boundaries in excess of state or federal limits as defined in the permit.*

*3. The owner or operator of an on-site sewage disposal system shall not:*

- (a) Cause or contribute to a violation of a water quality standard.*
- (b) Expand the system without approval from the Division or other administrative authority.*
- (c) Treat flows that are not typical domestic sewage, including, without limitation, swimming pool and spa discharges or water softener backwash.*
- (d) Treat flows from commercial operations that use hazardous substances or create hazardous waste.*
- (e) Create any condition which causes any public health, safety or environmental nuisance.*

*Sec. 56. 1. Except as otherwise provided in NRS 445A.600, the Division or other administrative authority may modify, revoke, suspend or cancel a permit at any time upon a determination by the Division or other administrative authority that the on-site sewage disposal system endangers the public health and safety or the environment and can only be regulated to acceptable levels by modification, revocation, suspension or cancellation of the permit.*

*2. The holder of a permit shall furnish to the Division or other administrative authority, within a period specified by the Division or other administrative authority, any information*

*which may be requested by the Division or other administrative authority to determine whether cause exists pursuant to subsection 1 for modifying, revoking, suspending or cancelling the permit or to determine whether the holder is in compliance with the conditions of the permit.*

**Sec. 57.** *1. Except as otherwise provided in this section, a request for a letter of approval to construct or an application for a permit to operate an on-site sewage disposal system submitted to the Division or other administrative authority must be denied if:*

*(a) The Division or other administrative authority determines that the proposed system will not comply with sections 3 to 89, inclusive, of this regulation;*

*(b) The proposed system is located within an area which is currently part of a plan prepared pursuant to section 208 of the Clean Water Act of 1977, 33 U.S.C. § 1288, prohibiting the use of on-site sewage disposal systems;*

*(c) The proposed system is located within an area for which the Division has issued a moratorium on on-site sewage disposal systems; or*

*(d) A public or community sewerage system, which includes in its jurisdiction the property where the proposed on-site sewage disposal system is located, is available, except that a letter of approval or permit may be granted by the Division or other administrative agency if the public or community sewerage system approves, in writing, the construction or operation of the proposed on-site sewage disposal system.*

*2. A denial by the Division or other administrative authority of a request for a letter of approval or a permit for an on-site sewage disposal system must be in writing and must specify the reasons for the denial.*

**Sec. 58.** *Except as otherwise provided in NRS 445A.605 and 445A.610:*

*1. A person who submits a request for a letter of approval to construct or an application*

*for a permit to operate an on-site sewage disposal system pursuant to sections 3 to 89, inclusive, of this regulation and who believes an action taken by the Division or other administrative authority is incorrect may, within 10 business days after receiving a notice of the action, request an informal discussion with the employee responsible for the action, together with the immediate supervisor of that employee.*

*2. If the aggrieved person does not believe the informal discussion resolves the situation, that person may, within 10 business days after the informal discussion, submit a written request to the Division for a formal conference. The formal conference must be scheduled for a date, time and place mutually agreed upon by the aggrieved person and the Division, except that the conference must be held not later than 60 days after the date the Division received the request. The Administrator or his appointee shall preside over the formal conference. The Division shall issue a determination, in writing, within 60 days after the formal conference.*

*3. The determination of the Division resulting from the formal conference may be appealed to the Director in writing within 10 days after receipt of the determination. The Director shall review the information provided in the formal conference and issue a determination not later than 60 days after the date on which the appeal was requested.*

**Sec. 59.** *1. A person shall not alter the design or increase the capacity of an existing on-site sewage disposal system without first obtaining a letter of approval from the Division or other administrative authority. The owner or operator must submit for approval:*

*(a) A statement justifying the alteration or increase, including, without limitation, any historical data indicating water meter readings or occupancy loads or other data requiring a change in the flow or design of the existing system; and*



*(b) If a new or altered treatment unit or effluent absorption area is proposed, the design specifications of the proposed system as required pursuant to section 52 of this regulation. The design specifications must bear the signature and original stamp of a design engineer.*

*2. The on-site sewage disposal system may continue operation under an existing general permit during construction for a period of 1 year or until construction is completed, whichever is less. If construction is not completed within 1 year, the holder of the general permit may request an extension in writing, which may be granted in increments of not more than 1 year by the Division or other administrative authority.*

*3. Upon completion of the construction, a new general permit must be issued by the Division or other administrative authority if the construction meets the requirements of sections 3 to 89, inclusive, of this regulation.*

**Sec. 60.** *An owner or operator of an on-site sewage disposal system shall submit annually all reports as specified in the permit. In addition to the information required by the permit, each annual report must include a written certification prepared by a maintenance provider indicating that:*

*1. The system has been maintained in accordance with sections 3 to 89, inclusive, of this regulation;*

*2. The system is operating in accordance with the approved design specifications and the operations and maintenance manual prepared pursuant to section 85 of this regulation; and*

*3. Testing samples required by the permit or the operations and maintenance manual, if any, have been analyzed and the results submitted to the Division or other administrative authority.*

**Sec. 61.** *A permit may be transferred to a new owner or operator of the on-site sewage disposal system upon application to the Division or other administrative authority. Until notice is given by the Division or other administrative authority that a permit is transferred, the owner or operator set forth on the face of the most recently issued or renewed permit is responsible for complying with sections 3 to 89, inclusive, of this regulation.*

**Sec. 62. 1.** *The setbacks, defined as the minimum horizontal separation, that must be maintained between the perimeter of the specific components of an on-site sewage disposal system and the listed features include:*

<i>Minimum Horizontal Distance, in clear, required from:</i>	<i>Building Sewer Drain</i>	<i>Septic or other Treatment Tank</i>	<i>Disposal Field</i>
<i>Building or structure</i>	<i>—</i>	<i>10'</i>	<i>10'</i>
<i>Property lines</i>	<i>10'</i>	<i>10'</i>	<i>10'</i>
<i>Water supply wells - domestic (sealed to 50 feet)</i>	<i>50'</i>	<i>100'</i>	<i>100'</i>
<i>Water supply wells (not sealed to 50 feet)</i>	<i>50'</i>	<i>100'</i>	<i>150'</i>
<i>Public water supply wells</i>	<i>50'</i>	<i>150'</i>	<i>150'</i>
<i>Streams or watercourses</i>	<i>50'</i>	<i>100'</i>	<i>100'</i>
<i>Drainage channels or irrigation ditches</i>	<i>25'</i>	<i>25'</i>	<i>25'</i>

<i>Minimum Horizontal Distance, in clear, required from:</i>	<i>Building Sewer Drain</i>	<i>Septic or other Treatment Tank</i>	<i>Disposal Field</i>
<i>Trees that may affect the disposal area (roots, shade, etc.)</i>	—	10'	10'
<i>Disposal fields</i>	—	5'	—
<i>Community water main line</i>	10'	25'	25'
<i>Individual water service line</i>	10'	25'	25'
<i>Dry wells</i>	—	10'	25'

2. *The Division or other administrative authority may increase the minimum distance specified in subsection 1 between a well and any component of an on-site sewage disposal system based on considerations which include, without limitation:*

- (a) The depth to the water table;*
- (b) The soil profile;*
- (c) The results of a groundwater mounding analysis, if required pursuant to section 45 of this regulation;*
- (d) A site located in a nitrogen management area; or*
- (e) A site located in a wellhead protection area as designated by the staff of the Groundwater Protection Branch of the Bureau of Water Pollution Control of the Division.*

**Sec. 63.** *A cleanout which conforms to the Uniform Plumbing Code, as adopted by reference in section 46 of this regulation, must be installed between each building drain and*

*each sewer line which leads to an on-site sewage disposal system. The cleanout must be located within 3 feet of the structure, or as close as practical if the design engineer determines that it cannot be placed within 3 feet of the structure. At least one additional cleanout must be placed for every 100 feet of sewer line, and at least one additional cleanout must be placed for each aggregate change in the direction of the sewer line in excess of 90 degrees.*

**Sec. 64. 1.** *Domestic sewage flowing to an on-site sewage disposal system must be treated by a treatment unit such as a septic tank, an aerobic wastewater treatment unit, a nitrogen removal wastewater treatment unit or other treatment unit approved by the Division or other administrative authority pursuant to sections 64 to 68, inclusive, of this regulation.*

**2.** *The Division or other administrative authority may require pretreatment of sewage entering the treatment unit of an on-site sewage disposal system if the sewage contains:*

- (a) A biochemical oxygen demand of more than 250 milligrams per liter;*
- (b) Total suspended solids of more than 150 milligrams per liter; or*
- (c) Total oil and grease of more than 20 milligrams per liter.*

**Sec. 65. 1.** *The minimum capacity of a septic tank used in an on-site sewage disposal system must be based on the projected daily sewage flow and other considerations specified in subsections 2 to 5, inclusive. The following table may be used to determine the projected daily sewage flow, using the occupancy that most closely resembles the anticipated occupancy of the building:*

<i>TYPE OF OCCUPANCY</i>	<i>PROJECTED FLOW OF SEWAGE (GALLONS PER DAY)</i>
<i>Airports</i>	<i>15 per employee and 5 per customer</i>
<i>Automobile washes (sand/oil interceptor required)</i>	<i>5 per passenger vehicle</i>
<i>Bowling alleys</i>	<i>150 per lane</i>

<i>TYPE OF OCCUPANCY</i>	<i>PROJECTED FLOW OF SEWAGE (GALLONS PER DAY)</i>
<i>Camps:</i>	
<i>Campground with central comfort station</i>	<i>35 per person</i>
<i>With flush toilets, no showers</i>	<i>25 per person</i>
<i>Day camps (no meals served)</i>	<i>15 per person</i>
<i>Summer and seasonal</i>	<i>50 per person</i>
<i>With cocktail lounge</i>	<i>Add 2 per meal served</i>
<i>With garbage disposal (not recommended)</i>	<i>Add 1 per meal served</i>
<i>With kitchen waste</i>	<i>Add 6 per meal served</i>
<i>With kitchen waste, disposable service</i>	<i>Add 2 per meal served</i>
<i>Schools:</i>	
<i>Teaching staff and other employees</i>	<i>20 per person</i>
<i>Kindergarten or elementary school</i>	<i>15 per pupil</i>
<i>Junior high school, middle school or high school</i>	<i>20 per pupil</i>
<i>With gym and showers</i>	<i>Add 5 per pupil</i>
<i>With cafeteria</i>	<i>Add 3 per pupil</i>
<i>Boarding school (including all waste)</i>	<i>100 per person</i>
<i>Service stations:</i>	
<i>With toilets</i>	<i>1,000 for first bay</i>
<i>Each additional bay</i>	<i>Add 500</i>
<i>Stores or shopping centers:</i>	
<i>Staff</i>	<i>20 per employee</i>
<i>With public restroom</i>	<i>1 per 10 square feet of floor space</i>
<i>Swimming pools (public)</i>	<i>10 per person</i>
<i>Theaters and auditoriums:</i>	
<i>Indoor</i>	<i>5 per seat</i>
<i>Drive-in</i>	<i>10 per space</i>

*2. If the projected daily sewage flow for the intended occupancy is 3,000 gallons or less per day, the minimum capacity of the septic tank must be equal to the projected daily sewage flow multiplied by 1.5.*

*3. If the projected daily sewage flow for the intended occupancy is more than 3,000 gallons per day, the minimum capacity of the septic tank must be equal to the projected daily sewage flow, with an additional sludge storage volume of 1,500 gallons.*

*4. If the projected daily sewage flow includes waste from recreational vehicles, the minimum capacity of the septic tank must be equal to the projected daily sewage flow multiplied by 2, to provide sufficient treatment capacity for the generally higher strength of recreational vehicle sewage and the common sanitary solution additives that inhibit microbial activity. In addition, increased pumping frequency must be specified in the operations and maintenance manual prepared pursuant to section 85 of this regulation.*

*5. Septic tanks serving establishments with high sewage volume, including, without limitation, restaurants, convenience stores and service stations located near interstate highway exits, require special sizing considerations. The minimum capacity of such a septic tank must be equal to the projected daily sewage flow multiplied by 3.*

**Sec. 66. 1. A septic tank included as part of an on-site sewage disposal system must:**

*(a) Be constructed of durable materials designed to withstand expected physical loads and corrosive forces.*

*(b) Be verified watertight by a test during installation.*

*(c) Be installed so that the tank is level.*

*(d) Be designed to provide for the settling of solids, the accumulation of sludge and scum, and access for cleaning.*

*(e) Meet the requirements of the Uniform Plumbing Code, ASTM International, or other recognized construction code or design manual for the construction of septic tanks, as referenced by the design engineer.*

*(f) Conform to guidelines established by the Division.*

*(g) Have a liquid depth of at least 36 inches. A liquid depth of more than 6 feet must not be considered in determining tank capacity.*

*(h) Have at least 12.5 percent of the tank volume for scum storage, with a minimum airspace of 9 inches.*

*(i) Except as otherwise provided in subsection 4, have two compartments. The capacity of the inlet compartment must not be less than two-thirds of the total capacity of the tank.*

*2. Septic tank inlets and outlets must allow free venting of tank gases back through the drainage system.*

*3. The top of the tee or baffle for both the vented inlet and vented outlet must extend at least 12 inches below the level of the liquid. The bottom of the tee or baffle for both the inlet and the outlet must extend at least 12 inches below the level of the liquid. The invert of the inlet pipe must be at least 2 inches above the invert of the outlet pipe.*

*4. Septic tanks may be installed in a series of not more than two. Each tank in the series must be a single compartment tank, and the volume of the first tank must not be less than two-thirds of the total capacity of both tanks.*

*5. Each compartment of the septic tank must have at least one manhole to provide access into the compartment. Each manhole must have a minimum diameter of 20 inches. If the inlet compartment is longer than 12 feet, an additional manhole must be provided over the baffle or partition wall. If the tank is longer than 30 feet, an additional manhole must be added for each*

*10 feet of length. Manholes must be designed to minimize odors and to prevent unauthorized entry.*

*6. The top of the tank must be at least 6 inches below the finished grade. If the top of the tank is more than 18 inches below the finished grade, each manhole required pursuant to subsection 5 must be extended to within 18 inches of the finished grade.*

*Sec. 67. 1. If the Division or other administrative authority determines that the degradation of groundwater or the constraints of the site of the on-site sewage disposal system require an effluent which is of a higher quality than that which would be produced by a septic tank, the Division or other administrative authority may require that the on-site sewage disposal system include an aerobic wastewater treatment unit.*

*2. The owner of an on-site sewage disposal system that will include an aerobic wastewater treatment unit must include in the design specifications submitted to the Division or other administrative authority a manual for the operation and maintenance of the aerobic wastewater treatment unit.*

*3. The owner of an on-site sewage disposal system that will include an aerobic wastewater treatment unit must include in the design specifications submitted pursuant to section 52 of this regulation a maintenance agreement with a service provider that covers the anticipated life span of the on-site sewage disposal system. The maintenance agreement must include, without limitation, provisions for an annual inspection of the system and its components which verifies that the system is:*

*(a) Operating correctly; and*

*(b) Producing effluent which has average daily maximum levels of 30 milligrams per liter or less each of total suspended solids and biochemical oxygen demand.*



*4. An aerobic wastewater treatment unit that produces effluent which has average daily maximum levels of more than 30 milligrams per liter of total suspended solids or biochemical oxygen demand must be repaired or replaced in accordance with this section before the unit may be used.*

*5. The design plans for an aerobic wastewater treatment unit must include a schematic detailing a 24-hour alarm system for monitoring the operation of the aerobic wastewater treatment unit.*

*6. Except in those cases where an aerobic wastewater treatment unit is required, an aerobic wastewater treatment unit is not allowed in areas where electrical service is unreliable, dependable maintenance is not available or intermittent use of the aerobic wastewater treatment unit adversely affects the operation of the on-site sewage disposal system.*

*7. The Division or other administrative authority may authorize a reduction in the size of the effluent absorption area for an on-site sewage disposal system if an aerobic wastewater treatment unit is used. Any reduction in the size of the effluent absorption area must be justified by the design engineer based on the conditions of the soil and the site.*

**Sec. 68.** *1. If the Division or other administrative authority determines that the degradation of groundwater or the constraints of the site of the on-site sewage disposal system require effluent which is of a higher quality than that which would be provided by a septic tank, the Division or other administrative authority may require that the on-site sewage disposal system include a nitrogen removal wastewater treatment unit.*

*2. A detailed hydrogeological study must be submitted by the design engineer which demonstrates that a nitrogen removal wastewater treatment unit will not increase the total*

*nitrogen concentration to more than 5 milligrams per liter in the groundwater beneath the site or at any down-gradient location.*

*3. A nitrogen removal wastewater treatment unit that produces effluent with a total nitrogen concentration of 20 milligrams per liter or more may not be approved by the Division or other administrative agency for use in areas where it has been documented that the total nitrogen concentration of the groundwater is 10 milligrams per liter or more.*

*4. The owner of an on-site sewage disposal system that will include a nitrogen removal wastewater treatment unit must include in the design specifications pursuant to section 52 of this regulation a manual for the operation and maintenance of the nitrogen removal wastewater treatment unit.*

*5. The owner of an on-site sewage disposal system that will include a nitrogen removal wastewater treatment unit must include in the design specifications submitted pursuant to section 52 of this regulation a maintenance agreement with a service provider that covers the anticipated life span of the on-site sewage disposal system. The maintenance agreement must include, without limitation, provisions for an annual inspection of the system and its components which verifies that the system is:*

*(a) Operating correctly; and*

*(b) Producing effluent which has total nitrogen concentrations of 20 milligrams or less per liter.*

*6. The design plans for a nitrogen removal wastewater treatment unit must include a schematic detailing a 24-hour alarm system for monitoring the operation of the nitrogen removal wastewater treatment unit.*

7. *Except in those cases where a nitrogen wastewater treatment unit is required, a nitrogen removal wastewater treatment unit is not allowed in areas where electrical service is unreliable, dependable maintenance is not available or intermittent use of the nitrogen removal wastewater treatment unit adversely affects the operation of the on-site sewage disposal system.*

8. *The Division or other administrative authority may authorize a reduction in the size of the effluent absorption area for an on-site sewage disposal system if a nitrogen removal wastewater treatment unit is used. Any reduction in the size of the effluent absorption area must be justified by the design engineer based on the conditions of the soil and the site.*

**Sec. 69. 1. Dosing tanks are required where:**

*(a) It is necessary to raise the elevation of wastewater for further treatment or disposal of sewage;*

*(b) Intermittent dosing of the disposal field is desirable;*

*(c) A pressure distribution system is used;*

*(d) More than 500 linear feet of absorption trench is required for the on-site sewage disposal system; or*

*(e) Soil conditions exist that require dosing, as determined by the design engineer or the Division or other administrative authority.*

2. *Alternate dosing is required for an on-site sewage disposal system with more than 1,000 feet of disposal pipe.*

3. *The frequency of dosing must be at least four times per day and not more than eight times per day.*

4. *A dosing tank must:*

*(a) Be designed to withstand anticipated internal and external loads under both full and empty conditions.*

*(b) Be easily accessible and have secured covers.*

*(c) Be watertight and anti-buoyant.*

*(d) Have risers to provide access to the inlet and outlet of the tank for inspection and service of internal components.*

*(e) Be vented.*

*5. A dosing tank must have sufficient volume for dosing which must be:*

*(a) Sufficient to distribute effluent evenly to all parts of the distribution system.*

*(b) Not less than 60 percent or more than 75 percent of the volume of the distribution piping, except for a pressure distribution system.*

*(c) Not less than 5 times or more than 10 times the volume of the distribution piping in a pressure distribution system.*

*6. A dosing tank must have a reserve volume which must be:*

*(a) Equal to the volume of the dosing tank between the alarm switch for high levels of effluent and the bottom of the invert of the inlet pipe;*

*(b) Of sufficient size to allow the on-site sewage disposal system to respond to a high-effluent level alarm within 2 hours or before the level of effluent in the dosing tank reaches the invert of the inlet pipe, whichever is longer; and*

*(c) Increased by the design engineer if the on-site sewage disposal system is located in a remote area.*

*7. If dosing tanks are screened, a reduction in the disposal field pipe opening may be allowed by the Division or other administrative authority.*

8. *If dosing is performed by an electric pump:*

*(a) The size of the pump must be determined according to the performance curves provided by the manufacturer of the pump, the flow rate required and the size of the pumping head as calculated by the design engineer.*

*(b) The control system for the dosing tank must include a switch to turn on the pump, a switch to turn off the pump and an alarm switch for high levels of effluent. A switch must be able to withstand the humid and corrosive atmosphere inside the dosing tank. The design engineer must include in the design specifications an information sheet provided by the manufacturer of each pump, switch and alarm to be used in the dosing tank. The alarm switch must be on a circuit that is separate from the circuit for the switches that turn the pump on and off. The alarm float must be located at a level which provides the required emergency reserve volume pursuant to subsection 6. In lieu of floats, a dosing timer may be acceptable and the design engineer must justify its use in the design specifications.*

*(c) All electrical contacts and relays must be mounted on the outside of the dosing tank to protect the electrical contacts from corrosion. The design engineer must take any action necessary to prevent sewer gases from traveling through the electrical conduit to the control box.*

*(d) A source of backup power must be available for the electric pump.*

*(e) The dosing tank vent must be located as far away from the control box as is practical, but in no case may the vent be closer than 3 feet from the control box.*

9. *The following is a diagram of a typical dosing tank with an electric pump:*

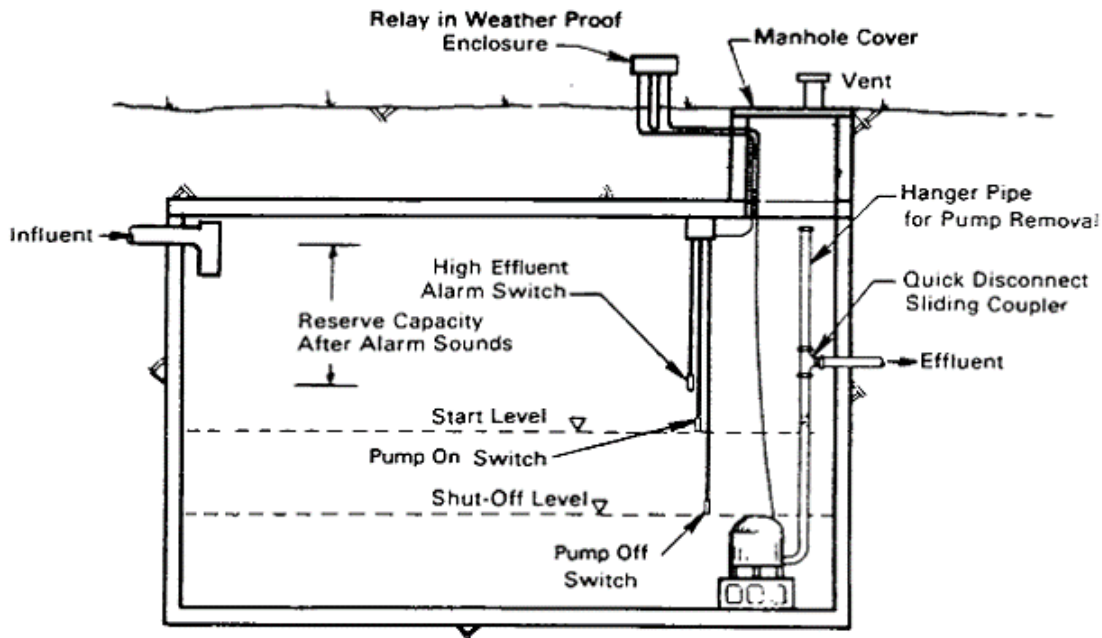

**Sec. 70. 1. *The effluent from a septic tank or other treatment unit must be disposed of through a soil absorption trench or other effluent absorption system pursuant to sections 70 to 82, inclusive, of this regulation and approved by the Division or other administrative authority.***

**2. *The size and type of effluent absorption system required for an on-site sewage disposal system must be determined according to:***

**(a) *The requirements for the sizing of the septic tank as determined pursuant to section 65 of this regulation;***

**(b) *The long-term acceptance rate calculations made pursuant to section 74 of this regulation; and***

**(c) *The results of percolation tests or other soils analyses conducted pursuant to section 71 or 72 of this regulation. The slowest percolation rate generated by the percolation tests or other soils analysis must be used to determine the required size of the effluent absorption area.***

*3. Soils used in an effluent absorption system must have a percolation rate that is 120 minutes per inch or less without interference from groundwater or impervious strata below the level of the effluent absorption system.*

*4. If the percolation test or other soils analysis yields a percolation rate of less than 5 minutes per inch, the Division or other administrative authority may require that:*

*(a) The effluent absorption area be specially designed by the design engineer to slow the effluent for proper treatment; and*

*(b) The required setbacks from any well or watercourses be increased.*

*5. The treatment unit and the effluent absorption system must be separated by at least 5 feet, and the solid watertight pipe that connects the treatment unit and the effluent absorption system must be placed on undisturbed soil.*

*6. Except as otherwise provided in this section, the distribution pipes must:*

*(a) Be of equivalent length unless otherwise authorized by the Division or other administrative authority.*

*(b) Consist of perforated drain pipe made of polyvinylchloride unless otherwise approved by the Division or other administrative authority.*

*(c) Be laid in such a manner that the bottom of the pipe is not less than 12 inches or more than 48 inches below the ground surface.*

*(d) Be laid in continuous straight or curved lines with a slope of not less than 2 inches or more than 4 inches per 100 feet of pipe.*

*(e) Be laid in such a manner that perforations are facing down.*

*(f) Be equipped with end caps or vented to the surface at the end of each pipe.*

*(g) Not exceed 110 feet in length unless a longer length is justified by the design engineer and approved by the Division or other administrative authority.*

*7. The effluent absorption area, including the site of the installed effluent absorption system and the backup area required pursuant to subsection 2 of section 45 of this regulation, must not be the site of activity that is likely, as determined by the Division or other administrative authority, to affect adversely the soil or the operation of the on-site sewage disposal system, which may include, without limitation, vehicular traffic, filling, cutting or other soil modification, or covering the area with a permanent structure, asphalt, concrete or a similar substance.*

*8. Monitoring ports must be located, at a minimum, in the center and at each end of the effluent absorption area. Additional monitoring ports may be included at representative points in the absorption area, as determined by the design engineer, to allow adequate assessment of the operating conditions and to measure any anticipated liquids at critical depths within the absorption bed or trench. The monitoring ports must be a minimum of 4 inches in diameter.*

*9. At least one down-gradient monitoring well, to sample groundwater quality in the area of the absorption area, may be required by the Division or other administrative authority, with additional wells required depending on the topography of the site and the size of the on-site sewage disposal system. Each well must extend to sufficient depths to sample seasonal fluctuations of the unconfined water table. The wells must conform to the guidelines for the design of groundwater monitoring wells established by the Division.*

*10. A distribution box must be used in an absorption system with more than one distribution line unless a pressure distribution system is used. Each distribution line must be separately connected to the distribution box. The number of outlets of a distribution box must*



*be equal to or more than the number of distribution lines to be used in the absorption area. The inverts of all outlet lines from a common distribution box must be set at the same level and must be above the level of the bottom of the distribution box. The inverts of all inlet lines to a common distribution box must be at least 1 inch higher than the level of the invert of the outlet lines from the same distribution box. A distribution box must:*

*(a) Be watertight and constructed of durable material that is resistant to corrosion, including, without limitation, concrete, fiberglass, polyethylene or any other material approved by the Division or other administrative authority.*

*(b) Be placed so that the box is level and must be maintained in that manner.*

*(c) Be designed to ensure equal flow.*

*(d) Have a cover that is made of the same material as the distribution box.*

*(e) Be installed on:*

*(1) Aggregate;*

*(2) A level concrete slab which is at least 6 inches in depth and which extends 6 inches or more beyond the perimeter of the distribution box; or*

*(3) Undisturbed soil.*

*11. Except as otherwise provided in this section, aggregate used in the effluent absorption area of an on-site sewage disposal system must have a minimum size of 3/4 inch and a maximum size of 2 1/2 inches. The aggregate must be durable and inert so that it will maintain its integrity and not collapse or disintegrate with time and must not be detrimental to the performance of the system.*

*12. Except as otherwise provided in this section, the bottom of the absorption system disposal field must be at least 4 feet above the level of the seasonal high groundwater of the site.*

**Sec. 71. 1.** *If a percolation test is performed pursuant to section 50 of this regulation, the test must be performed by a qualified person, including, without limitation, a design engineer, a soils scientist or a geologist, approved by the Division or other administrative authority, and must be performed in accordance with this section.*

*2. The percolation test data must be taken from a minimum of two test holes in the area of the proposed effluent absorption system. The person conducting the percolation test must:*

*(a) Dig or bore the test holes to the proposed depth of the absorption system.*

*(b) Ensure that the test holes have vertical sides and are not less than 4 inches or more than 12 inches in width.*

*(c) Scratch the bottom and side surfaces of the test holes with a sharp or pointed instrument to expose the natural soil interface.*

*(d) Remove all loose material from the bottom of the test holes.*

*(e) Add at least 2 inches of coarse sand or gravel aggregate to the bottom of the test holes to prevent scouring.*

*(f) Remove any soil which sloughs into the holes before or during the percolation test.*

*3. To determine which percolation test procedure to follow, the person conducting the test must:*

*(a) Fill the percolation hole with water to a depth of at least 12 inches over the aggregate and determine the time required for the water to seep completely away.*

*(b) Fill the percolation hole with water again to a depth of at least 12 inches over the aggregate and determine if the water seeps away in 10 minutes or less and:*

*(1) If water is left in the hole after 10 minutes, proceed with the presoaking procedure pursuant to subsection 4, followed by the slow percolation test procedure pursuant to subsection 5; or*

*(2) If the water is completely seeped away after 10 minutes, proceed with the fast percolation test procedure pursuant to subsection 6.*

*4. The presoaking procedure for the slow percolation test consists of the following steps:*

*(a) Fill the percolation hole with clear water to a minimum depth of 12 inches over the aggregate.*

*(b) Add clear water as required to maintain at least 12 inches of water over the aggregate in the hole for 4 hours.*

*(c) Allow any water remaining in the hole after 4 hours to seep away. Do not remove the water.*

*(d) Let the hole sit for not less than 16 hours or more than 30 hours before beginning the slow percolation test. Swelling of the soil may occur during this period. Do not disturb the soil.*

*5. The slow percolation test consists of the following steps:*

*(a) Not less than 16 hours or more than 30 hours after the end of the presoaking procedure 4-hour soaking period, fill the hole with clear water to a maximum depth of 6 inches over the aggregate.*

*(b) From a fixed reference point, measure the drop in the level of the water at 30-minute intervals, for a total test time of 4 hours. If the first 6 inches of water seeps away in less than*

*30 minutes, the interval between measurements must be reduced from 30-minute intervals to 10-minute intervals, for a total test time of 1 hour.*

*(c) Fill the hole to a maximum depth of 6 inches over the aggregate as often as necessary to prevent the hole from becoming empty during the test time.*

*(d) The amount of the drop in the level of the water during the last interval of the test must be used to determine the percolation rate, except that if two successive measurements do not vary more than 1/16 inch, the test may be stopped and the percolation rate determined by the last two measurements. In any case, the minimum time in which a slow percolation test may be completed is 1 hour.*

*6. The fast percolation test consists of the following steps:*

*(a) Fill the percolation hole with clear water to a maximum depth of 6 inches over the aggregate.*

*(b) From a fixed reference point determine, at 10-minute intervals, the extent to which the water in the hole drops over the next 1 hour. If 6 inches of water seeps away in less than 10 minutes, a shorter interval between measurements must be used, but the minimum time for the entire test is 1 hour.*

*(c) Refill the hole as necessary to prevent all the water from seeping away during the 1-hour test time. The level of the water must never exceed 6 inches in depth over the aggregate.*

*(d) The amount of the drop in the level of the water recorded for the final 10-minute interval must be used to determine the percolation rate.*

**Sec. 72. 1.** *In lieu of performing a percolation test, the design engineer, soils scientist or geologist performing an investigation of soil characteristics to prepare an engineering report pursuant to section 50 of this regulation may include a determination of soil*

*characteristics using an alternative method described in one or more of the following publications:*

*(a) Standard Practice for Surface Site Characterization for On-Site Septic Systems, published by ASTM International, document number ASTM D5879-95(2003).*

*(b) Standard Practice for Subsurface Site Characterization of Test Pits for On-Site Septic Systems, published by ASTM International, document number ASTM D5921-96(2003)e1.*

*(c) Standard Practice for Soil Investigation and Sampling by Auger Borings, published by ASTM International, document number ASTM D1452.07a(2007).*

*↪ The above publications are hereby adopted by reference and are available from ASTM International at 100 Barr Harbor Drive, P.O. Box C700, West Conshohocken, Pennsylvania, 19428-2959, by telephone at (610) 832-9585, by facsimile at (610) 832-9555 or at the Internet address <http://www.astm.org>, for the price of \$31 for the publications in paragraphs (a) and (c) and \$42 for the publication in paragraph (b).*

*2. A design engineer may investigate soil characteristics using another method of soil evaluation that ensures compliance with NRS 445A.300 to 445A.730, inclusive, and sections 3 to 89, inclusive, of this regulation, as determined by the Division or other administrative authority.*

**Sec. 73.** *The following is a table which must be used for the classification of soils types:*

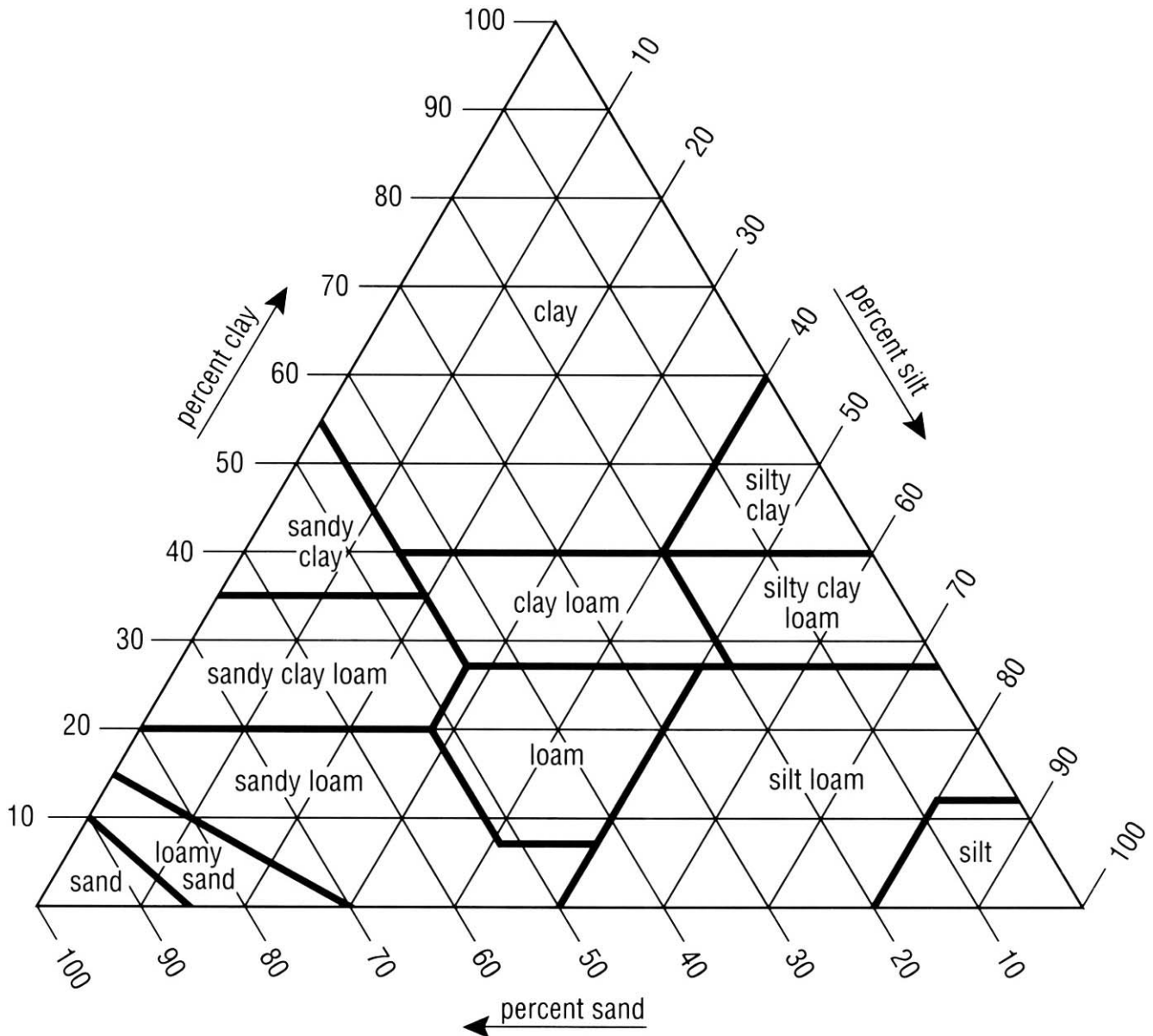

**Sec. 74. 1. *The required size of the effluent absorption area for an on-site sewage disposal system must be calculated based on the long-term acceptance rate of the soil at the site, unless the system uses an elevated mound system or an intermittent sand filter system for effluent absorption. An elevated mound system or an intermittent sand filter system must use the table set forth in section 80 of this regulation for determining the size of the absorption***

area. The long-term acceptance rate, as determined by either the percolation rate of the soil or soil texture, must be determined in accordance with the following table:

*Long-Term Acceptance Rates (LTAR) for Wastewater Application to Soil Absorption Systems*

<i>Percolation Rate (minutes/inch)</i>	<i>Typical Soil Textures</i>	<i>Maximum Loading Rate/LTAR (gallons/square foot/day)</i>
<i>≤ 5</i>	<i>Gravel to Coarse to Medium Sand</i>	<i>See Section 70 of this regulation</i>
<i>6-10</i>	<i>Fine Sand to Loamy Sand</i>	<i>1.1</i>
<i>11-20</i>	<i>Sandy Loam to Loam</i>	<i>1.0</i>
<i>21-30</i>	<i>Loam</i>	<i>0.7</i>
<i>31-40</i>	<i>Loam to Silty Loam</i>	<i>0.5</i>
<i>41-60</i>	<i>Clay Loam to Clay</i>	<i>0.4</i>
<i>Over 60</i>	<i>Silty Clay Loam/Silty Clay</i>	<i>0.2</i>

2. The absorption area required for an on-site sewage disposal system, unless an elevated mound system or intermittent sand filter system is used, must be calculated as  $Q/LTAR=A$ , where:

- (a) “A” is the absorption area required;
- (b) “Q” is the average projected daily sewage flow based on septic tank or other treatment unit size; and
- (c) “LTAR” is the long-term acceptance rate of the soil at the site.

↪ *For example, if a 3,000 gallon septic tank is proposed and the site consists of loam with a long-term acceptance rate of 0.7 gallons per square foot per day, the calculation would be 3,000 gallons per day divided by 0.7 gallons per square foot per day for a total required absorption area of 4,286 square feet. Thus, the required septic tank capacity determined from the table set forth in section 65 of this regulation must be divided by the long-term acceptance rate from the table set forth in this section to determine the minimum absorption area required.*

**Sec. 75. 1.** *An on-site sewage disposal system may use absorption trenches as the effluent absorption system, unless limiting conditions exist at the site which preclude such use, including, without limitation, high groundwater, highly permeable stratum, sloping terrain, shallow bedrock or a layer of semi-impervious soil with a percolation rate that is slower than 120 minutes per inch. In such a case, an alternative effluent absorption system may be used in accordance with sections 76 to 82, inclusive, of this regulation.*

*2. An absorption trench system used in an on-site sewage disposal system must meet the following design and construction criteria:*

*(a) The trench must not be excavated if the soil is saturated. Surfaces in a trench which are smeared or compacted must be scarified to the depth to which the soils are smeared or compacted, and all loose material must be removed.*

*(b) The bottom of the trench must be level and must not be less than 1 foot or more than 3 feet in width.*

*(c) The length of each trench and the number of trenches needed must be determined by calculating the total absorption area required pursuant to subsection 3.*



*(d) The distance between trenches must be at least 4 feet, with an additional 2 feet added for each foot of depth of the trench below the bottom of the distribution piping. The depth must be measured from the centerline of the trench.*

*(e) The distribution pipe in each trench must be placed in clean, graded aggregate ranging in size from 3/4 inch average diameter to 2 1/2 inches in diameter. The aggregate must extend from at least 2 inches above the distribution pipe to at least 12 inches below the distribution pipe. If the trench is more than 6 feet below the finished grade, the aggregate must extend not less than 12 inches below the ground surface to avoid anaerobic conditions in the trench.*

*(f) The aggregate in the trench must be covered with untreated building paper, straw with a minimum thickness of 1 inch, geotextile fabric or a similar covering approved by the Division or other administrative authority. The top of the trench must be backfilled with not less than 4 inches or more than 6 inches of soil, and fines must be kept from entering the trench from poorly cleaned gravel or poorly cleaned cover. As used in this paragraph, "fines" means any small, crushed or powdered material which may seriously impair the absorption ability of the aggregate used in an absorption trench.*

*3. The total absorption area of the trench must be determined by measuring the size of the effective area of each sidewall of the trench beneath the distribution pipe. Not more than 4 feet of aggregate below the distribution pipe may be used to calculate the effective area of the sidewall unless approved by the Division or other administrative authority. To determine the required length of the absorption trench to meet the total absorption area requirement for the on-site sewage disposal system as calculated pursuant to section 74 of this regulation, the total absorption area required, in square feet, must be divided by 2 times the depth, in feet, of the aggregate beneath the distribution pipe. The depth of the aggregate must be multiplied by 2 to*

*account for both sidewalls of the trench. For example, if the required absorption area is calculated at 3,000 square feet and the aggregate below the distribution pipe is 4 feet deep, the equation would be  $3,000 \text{ feet squared} / (4 \text{ feet} \times 2) = 375 \text{ linear feet of distribution pipe}$ , and thus absorption trench, required.*

*4. The following is a diagram of an absorption trench:*

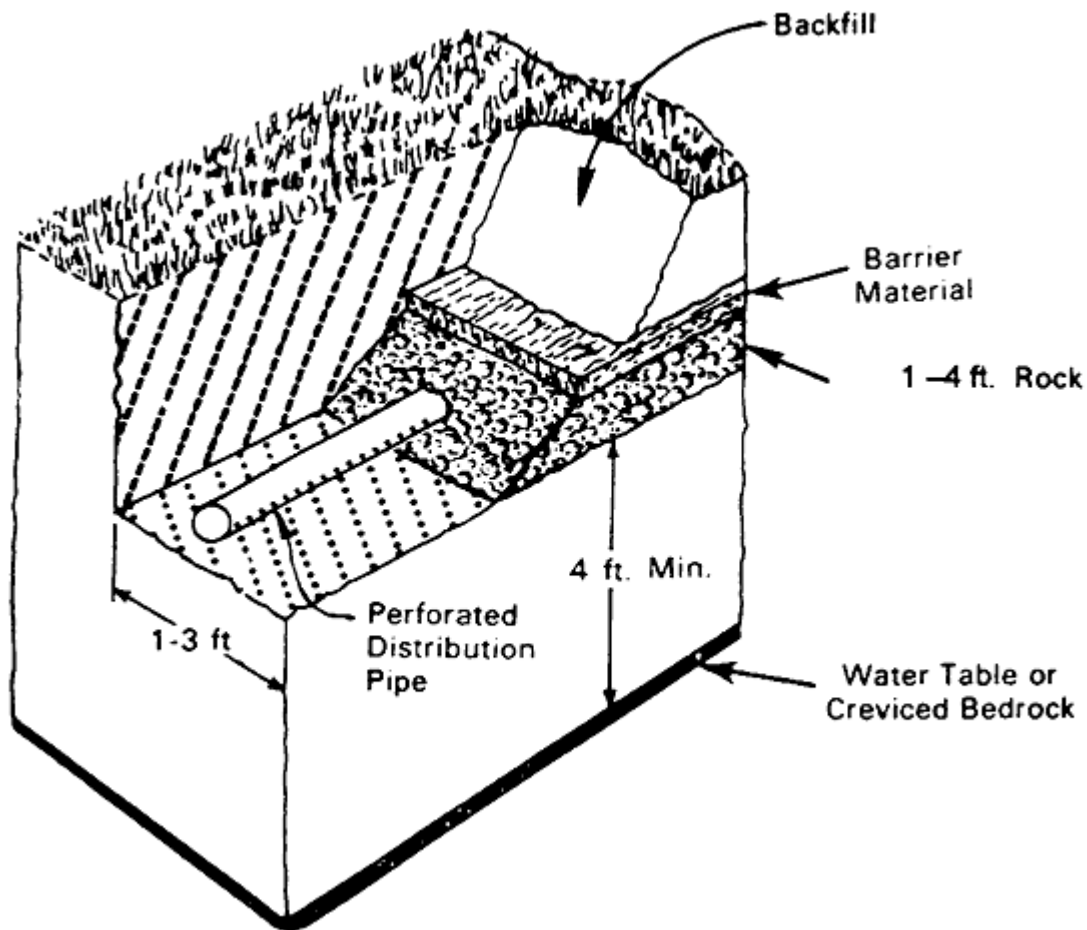

**Sec. 76. 1. *If an on-site sewage disposal system cannot use absorption trenches pursuant to section 75 of this regulation because of limiting conditions, including, without limitation, high groundwater, highly permeable stratum, sloping terrain or shallow bedrock,***

*the Division or other administrative authority may approve the use of an alternative absorption system.*

*2. Any plumbing fixture served by an alternative absorption system must be a low-flow fixture designed for an on-site sewage disposal system that is used where the percolation rates are slower than 60 minutes per inch. Each such fixture must be specifically identified by the design engineer on the design specifications for the alternative absorption system.*

*3. A design engineer who is designing an alternative absorption system must consult the Design Manual: On-site Wastewater Treatment and Disposal Systems and the On-site Wastewater Treatment Systems Manual, both of which are adopted by reference pursuant to section 46 of this regulation.*

*4. In addition to the provisions of subsection 3, a design engineer who is designing an alternative absorption system must contact and consult with the Division or other administrative authority concerning design parameters before submitting design specifications pursuant to section 52 of this regulation.*

**Sec. 77.** *1. If the use of an absorption trench is not practical, an absorption bed may be used in lieu of an absorption trench, if justified by the design engineer. The bottom of the absorption bed must serve as the primary absorptive medium.*

*2. An absorption bed used in an on-site sewage disposal system must meet the following design and construction criteria:*

*(a) The absorption bed must not be placed on a slope with a grade of more than 5 percent.*

*(b) The bottom of the absorption bed must be level.*

*(c) The percolation rate of the soils at the bottom of the absorption bed must not be more than 60 minutes per inch.*

*(d) The area of the sidewall or the depth of the aggregate beneath each distribution pipe must not be less than 12 inches or more than 36 inches.*

*(e) An absorption bed must have at least two distribution pipes, which must not be less than 4 feet or more than 6 feet apart and laid with perforations facing down. The distribution pipes must be:*

*(1) Level and placed not less than 3 feet or more than 6 feet from the sidewalls of the bed;*

*(2) Not longer than 110 feet;*

*(3) Placed on at least 12 inches of clean, graded aggregate and covered by at least 2 inches of aggregate; and*

*(4) Not less than 4 inches in diameter,*

*↳ unless a pressure distribution system is used. Distribution pipes used in a pressure distribution system must meet the requirements for a pressure distribution system set forth in section 82 of this regulation.*

*3. The invert of the piping for the drain field must not be less than 12 inches or more than 48 inches below the finished grade.*

*4. The aggregate covering the distribution pipe must be covered with untreated building paper, straw with a minimum thickness of 1 inch, geotextile fabric or a similar covering approved by the Division or other administrative authority.*

*5. The top of the absorption bed must be at least 6 inches below the surface of the natural soil.*

*6. A capping fill of soil must be placed on top of the absorption bed. The capping fill must:*

(a) *Extend at least 10 feet beyond the perimeter of the leaching area of the absorption bed;*  
*and*

(b) *Be placed at a minimum depth of 12 inches above the finished grade to allow for settling.*

7. *If more than 500 linear feet of distribution pipe is used, dosing is required pursuant to section 69 of this regulation,*

8. *The owner or operator of an on-site sewage disposal system must take such precautions as are necessary to prevent compacting the bottom of the absorption bed. Any loose or smeared soil must be raked and removed. No vehicles may travel on the area of the absorption bed during excavation or after excavation is completed.*

9. *The following is a diagram of an absorption bed:*

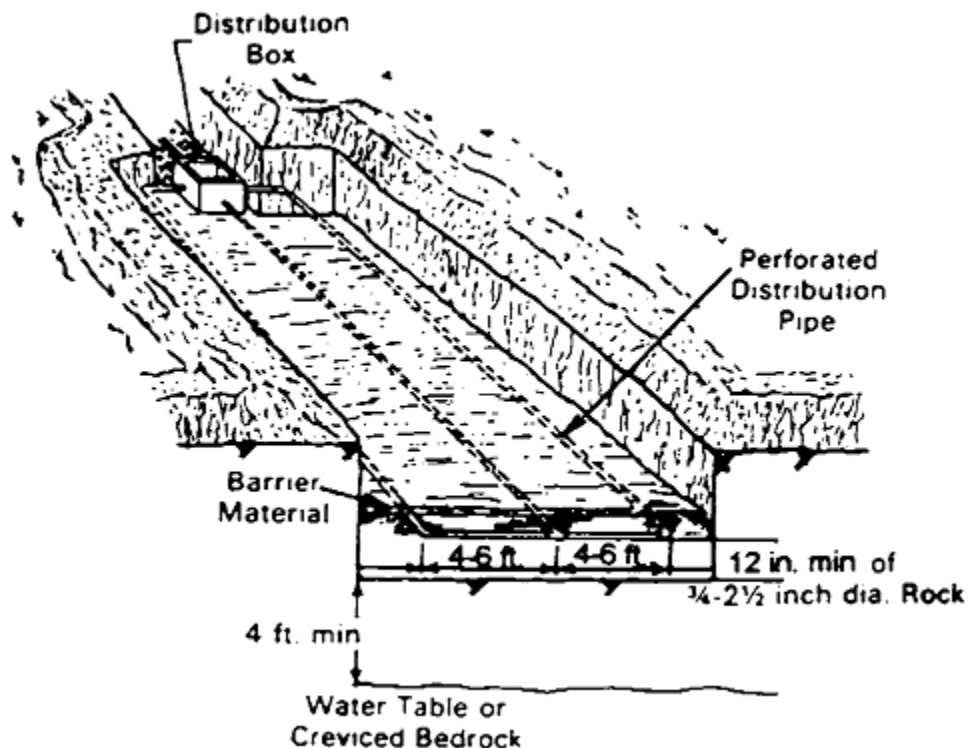

**Sec. 78. 1.** *On sloping terrain where a conventional absorption trench or bed system cannot be installed or is not practical, a stepped network of trenches using relief lines between the trenches may be used.*

*2. A design engineer who includes a stepped network of trenches using relief lines in the design specifications for an on-site sewage disposal system must expressly justify the use of such a system.*

*3. A stepped network of trenches utilizing relief lines must allow the effluent from a completely filled trench to overflow through relief lines into a trench at a lower elevation, as shown in subsection 8.*

*4. The size of the absorption area required for a stepped network of trenches using relief lines must be calculated based on the long-term acceptance rates set forth in section 74 of this regulation, and must conform to the requirements for sizing a standard absorption trench pursuant to section 75 of this regulation. Percolation testing or soils analyses conducted pursuant to section 71 or 72 of this regulation must be performed at the location of each stepped trench. The size of the required absorption area must be calculated based on the slowest percolation rate or the most restrictive soil found.*

*5. Trenches for a stepped network of trenches using relief lines must be spaced at least 10 feet apart.*

*6. The leaching aggregate must extend at least 4 inches above the top of the distribution pipe. The depth of aggregate beneath the distribution pipe is site-specific and must be determined by the design engineer with approval from the Division or other administrative authority.*

7. *The invert of the relief line must be located not less than 1 inch or more than 2 inches above the top of the distribution pipe.*

8. *The following is a diagram of a stepped network of trenches utilizing relief lines:*

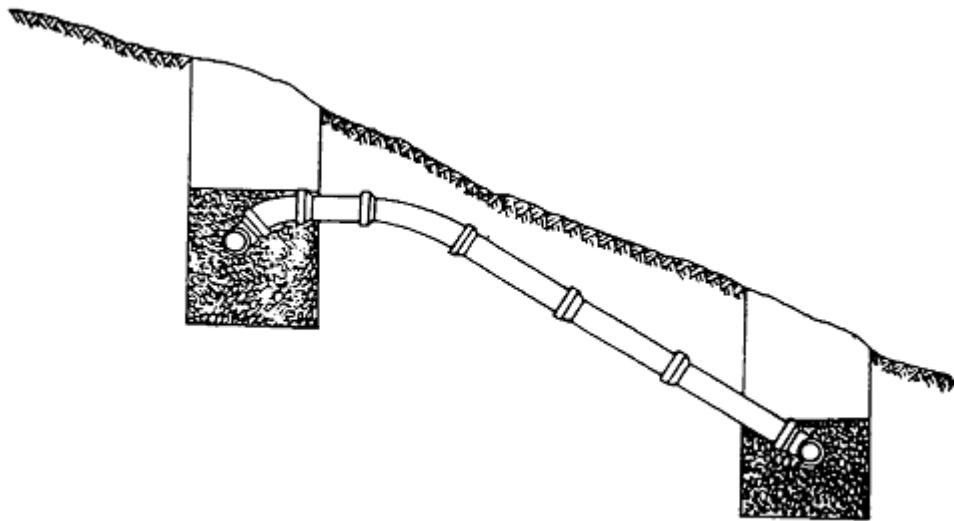
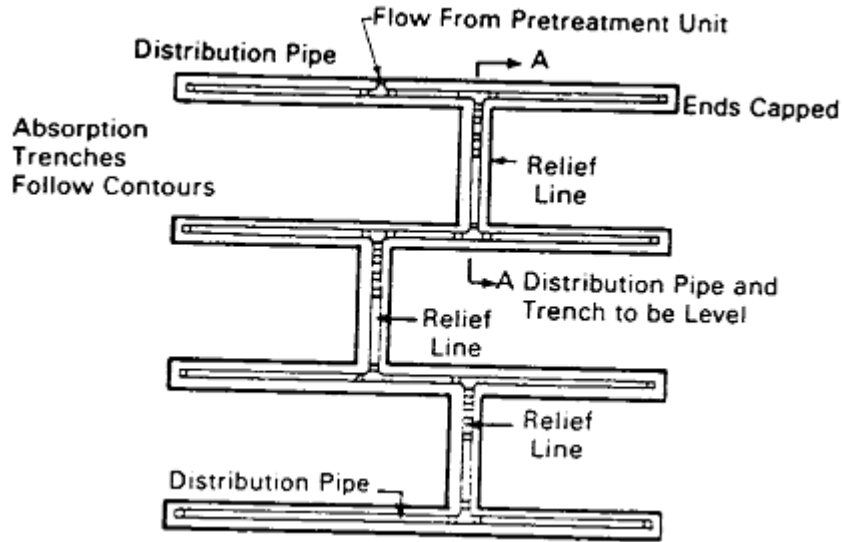

Sec. 79. 1. *Except as otherwise provided in subsection 2, a capping fill trench may be used where conditions relating to high groundwater prohibit the installation of an absorption trench pursuant to section 75 of this regulation.*

2. *A capping fill trench must not be used if the soil in which the capping fill is to be placed is saturated.*
3. *The soil surrounding and beneath the bottom of a capping fill trench must have a percolation rate that is more than 10 minutes per inch but less than or equal to 120 minutes per inch. A capping fill trench must not be installed on a slope that is more than 5 percent with a percolation rate slower than 60 minutes per inch, but may be installed on a slope of not more than 10 percent if the percolation rate is equal to or faster than 60 minutes per inch.*
4. *The required absorption area of the capping fill trench must be determined by calculating the size of the effective sidewall pursuant to section 75 of this regulation.*
5. *A minimum depth of 4 feet must be maintained between the bottom of the capping fill trench and the level of the seasonal high groundwater or any impermeable barrier or other limiting feature.*
6. *The invert of the distribution pipe must be placed less than 12 inches below the existing grade of the native soil. At least 2 inches of aggregate must be placed over the distribution pipe. The depth of aggregate beneath the distribution pipe is site-specific and must be determined by the design engineer with approval from the Division or other administrative authority.*
7. *The aggregate covering the distribution pipe must be covered with untreated building paper, straw with a minimum thickness of 1 inch, geotextile fabric or a similar covering approved by the Division or other administrative authority.*
8. *Each capping fill trench must be constructed before the capping fill is constructed.*
9. *The existing vegetative mat in the fill area must be disrupted by scarification or plowing to remove roots and other organic matter that may slow the percolation rate. The soil*



*to be used as capping fill must be of a texture similar to the native soil. The native soil and the capping fill must be mixed at their point of interface.*

*10. The capping fill must:*

*(a) Be placed over the aggregate and the cover set forth in subsection 7 to a depth of not less than 12 inches or more than 18 inches.*

*(b) Be graded to provide positive drainage away from the absorption trenches and toward the perimeter of the capping fill.*

*(c) Be placed in such a manner as to prevent the compaction of the scarified soil at the interface of the native soil and capping fill.*

*(d) Extend at least 10 feet beyond the sidewall of the absorption trench.*

*11. Plant vegetation must be established on the top of the fill area to reduce the potential for the erosion of the capping fill.*

*12. The owner or operator of the on-site sewage disposal system must take such precautions as are necessary to prevent the compaction of the capping fill, including, without limitation, prohibiting vehicle travel on the capping fill.*

*13. The following is a diagram of a capping fill trench:*

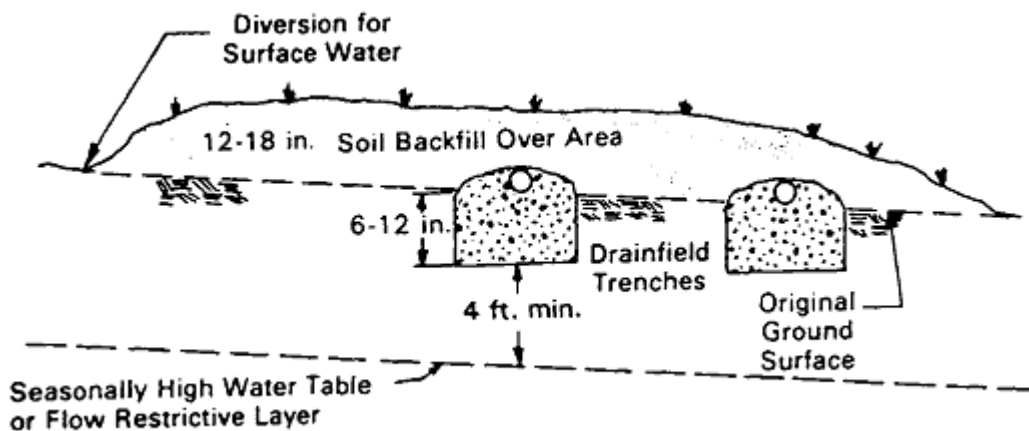

**Sec. 80. 1.** *An elevated mound system consists of a suitable fill material, an absorption area made of coarse aggregate and fill material with a distribution network, and a soil cap. In an elevated mound system, the effluent must be gravity fed, pumped or siphoned into the upper part of the absorption area through a distribution network. The effluent must pass through the aggregate and the fill material, with treatment of the wastewater occurring as it passes through the fill material and the unsaturated zone of the native soil.*

*2. In preparing an elevated mound system, the site must be scarified, except that tree stumps and other herbaceous materials must be left in place after mowing or cutting to prevent excessive alteration of the soil structure. Mound construction must begin immediately after scarification, and each layer of the absorption system must be placed in such a manner as to prevent differential settling and to promote uniform density.*

*3. An elevated mound system must not be constructed on a slope that is:*

*(a) More than 6 percent if the soils comprising the slope have percolation rates slower than 60 minutes per inch; or*

*(b) More than 12 percent if the soils comprising the slope have percolation rates equal to or greater than 60 minutes per inch.*

*4. Percolation tests must be conducted at the depth estimated by the design engineer as being the point of interface between the native soil and the fill material and at a depth of 20 inches below the surface of the native soil. The size of the required area for the elevated mound system must be based on the slowest percolation rate obtained.*

5. *The basal absorption area of an elevated mound system must be sufficiently large to absorb the wastewater before it reaches the perimeter of the elevated mound. The infiltration rates for determining the size of the basal absorption area are as follows:*

<i>Percolation Rate or Equivalent Soil Classification (minutes per inch)</i>	<i>Infiltration Rate (gallons per day per square foot)</i>
<i>0-30</i>	<i>1.0</i>
<i>31-45</i>	<i>0.5</i>
<i>46-60</i>	<i>0.3</i>
<i>61-120</i>	<i>0.2</i>

6. *The absorption area required for an elevated mound system must be determined from the table set forth in subsection 5. In addition, if the site on which the elevated mound system will be located is:*

(a) *Flat, the entire basal area, calculated as length multiplied by width, must be used to determine the absorption area of the elevated mound system.*

(b) *Sloping, only the area below and down slope from the absorption bed must be used to determine the absorption area of the elevated mound system, calculated as  $W \times (L+S)$ , where:*

(1) *“W” is the width of the absorption bed;*

(2) *“L” is the length of the absorption bed; and*

(3) *“S” is the required side slope of the elevated mound pursuant to subsection 9, as measured from the edge of the absorption bed to the perimeter of the mound.*

7. *At least 4 feet of unsaturated soil or fill material, or any combination thereof, must be maintained between the bottom of the mound system and the top of the seasonal high groundwater or any impervious barrier, including, without limitation, any bedrock. On sloping sites, the depth of unsaturated soil and fill material must be increased to maintain a level bed.*

8. *If practicable, the bed for an elevated mound system must be rectangular with a long axis that is parallel to the contour of the slope to minimize the possibility of seepage from the base of the elevated mound. If the natural soil has a percolation rate that is less than 60 minutes per inch, the bed must be made narrow and extend along the contour of the slope as far as practicable. The bed must be filled at least 9 inches deep with clean, graded aggregate.*

9. *The side slopes of an elevated mound system must extend in a horizontal to vertical ratio that is at least 3 to 1.*

10. *The aggregate in the absorption bed must be covered with untreated building paper, straw with a minimum thickness of 1 inch, geotextile fabric or a similar covering approved by the Division or other administrative authority.*

11. *After placement of the covering required pursuant to subsection 10, the entire absorption bed must be covered with at least 1 foot of topsoil. The topsoil cap, which must be placed at the center of the mound, must maintain a minimum slope of 2 percent away from the crown.*

12. *The following is a diagram of an elevated mound:*

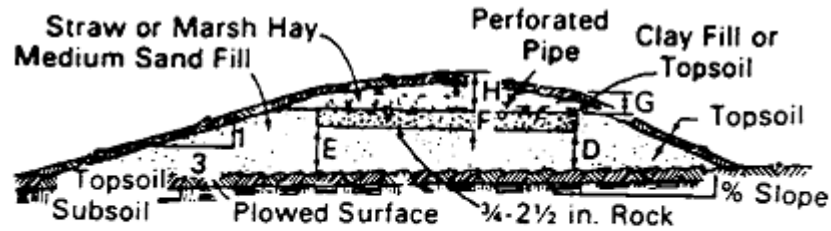

(A) Cross Section

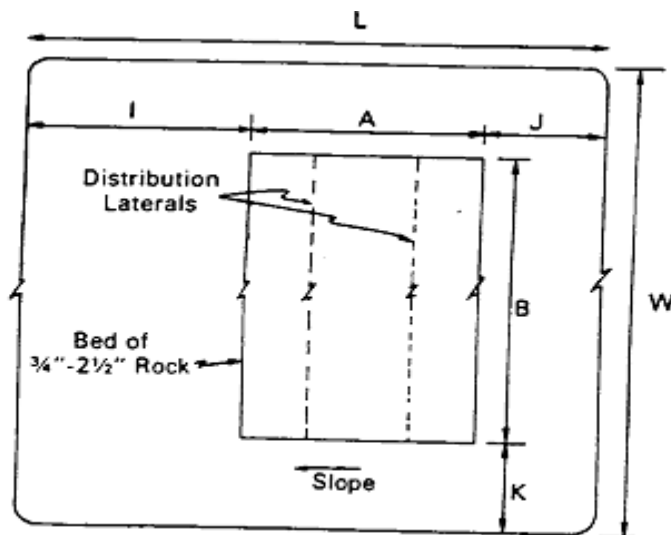

(B) Plan View

Sec. 81. 1. *In an intermittent sand filter system, the effluent must be pumped or siphoned into the absorption area and through a distribution network located in the upper part of a sand filter containment vessel. The upper part of the vessel must be made of coarse aggregate. The effluent must pass through the aggregate and then infiltrate the filter media below. Treatment of the effluent must occur as it passes through the filter media and into the unsaturated zone of the natural soil.*

2. *The pressurized wastewater delivery system must provide even distribution in the sand filter through good engineering practice. The design engineer must:*

*(a) Specify all necessary controls, pipes, valves, orifices, filter cover materials, gravel or other distribution media, including, without limitation, monitoring and servicing components in the design specifications submitted pursuant to section 52 of this regulation; and*

*(b) Ensure that the topsoil cover is not less than 6 inches or more than 12 inches in depth and graded to drain off the top of the sand filter.*

*3. Pressurized wastewater delivery must be applied from the septic tank or separate watertight treatment unit chamber with a pump or siphon that is sized and controlled to deliver the pretreated wastewater to the top of the intermittent sand filter. The dosing rate must not be less than 4 doses or more than 24 doses per day.*

*4. The vessel containing the sand filter must be watertight, structurally sound, durable and capable of withstanding stress from installation and operational service. The intermittent sand filter system may be placed above grade, partially buried or fully buried depending on site and service specifications and must be justified by the design engineer in the design specifications submitted pursuant to section 52 of this regulation.*

*5. The filter media used in the intermittent sand filter system must consist of washed, durable granular material with less than 1 percent organic matter by weight. The effective size of the filter media must not be less than 0.25 millimeter or more than 1.0 millimeter. The uniformity coefficient of the filter media must be less than 4.*

*6. The depth of the filter media must be at least 24 inches, and the top and bottom surfaces of the filter media must be level.*

*7. The filter media used in the intermittent sand filter system must meet the following criteria:*

*Filter Media Specifications*

<i>Sieve Size</i>	<i>Effective Particle Size</i>	<i>Percent by Weight Passing Sieve</i>
<i>3/8"</i>	<i>9.50 mm</i>	<i>100</i>
<i>4</i>	<i>4.75 mm</i>	<i>95-100</i>
<i>8</i>	<i>2.36 mm</i>	<i>80-100</i>
<i>16</i>	<i>1.18 mm</i>	<i>50-85</i>
<i>30</i>	<i>0.60 mm</i>	<i>25-60</i>
<i>50</i>	<i>0.30 mm</i>	<i>10-30</i>
<i>100</i>	<i>0.15 mm</i>	<i>2-10</i>

*Source: ASTM C-33, "Specifications for Fine Aggregate"*

*The filter media must not have more than 45 percent passing any one sieve and retained on the next consecutive sieve of those shown in the table above. The fineness modulus must not be less than 2.3 or more than 3.1. As used in this subsection, "fineness modulus" means the sum of the cumulative percentages retained in the sieve analysis, divided by 100, for the sieve sizes shown in the table above.*

*8. The required size of the intermittent sand filter system depends on the projected daily sewage flow of the on-site sewage disposal system. The maximum wastewater loading rate is 1 gallon per day per square foot of inlet surface at the rated projected daily sewage flow. For*

example, a system with a flow of 4,000 gallons per day would require a sand filter of at least 4,000 square feet.

9. The native soil portion of the absorption system must be designed to ensure that the linear loading rate does not exceed the disposal capability at the site.

10. The following is a diagram of an intermittent sand filter system:

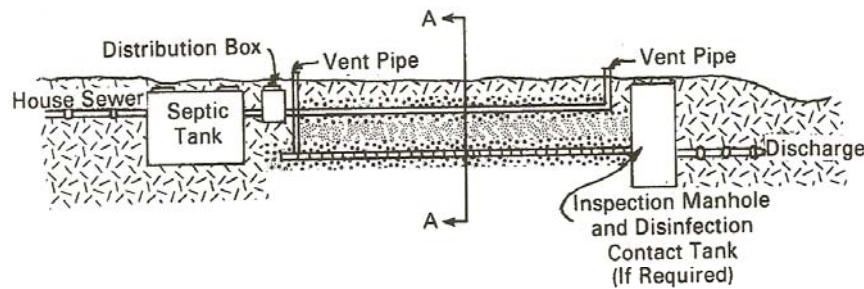

Profile

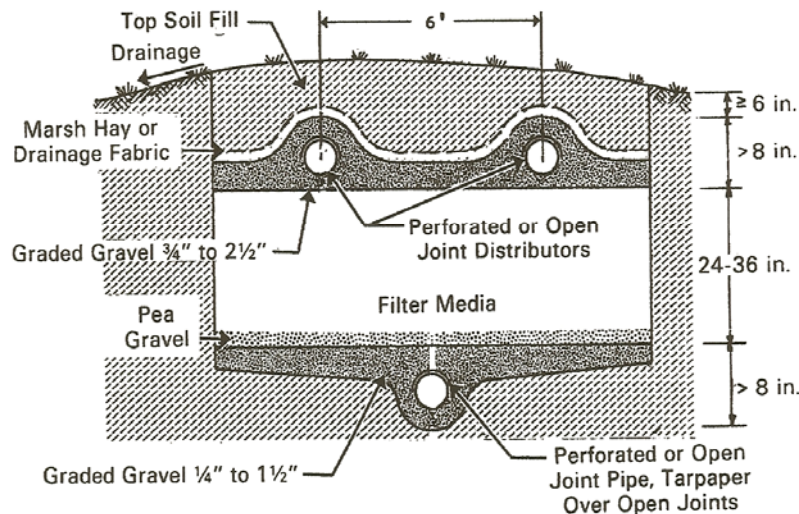

Sec. 82. 1. A pressure distribution system may be used in conjunction with any effluent absorption system that uses distribution pipes. A pump must be used to pressurize the pressure distribution system.



2. The active dosing volume of a pressure distribution system must be approximately 10 times the total volume of the distribution pipe used in the effluent absorption system.

3. A solid delivery pipe which connects the dosing tank to the perforated distribution piping must be placed below the frost line. The delivery pipe must maintain a downward slope from the distribution lines to the dosing tank to ensure drainage between discharges. The use of check valves and other devices that prevent backflow to the pump is prohibited.

4. To reduce the potential for plugging and clogging of distribution pipes, the diameter of the discharge hole must be at least 3/8 inch. If an effluent screen is used, the diameter of the discharge hole may be reduced accordingly. The rate of discharge for various-sized holes at various pressures are set forth in the following table:

<i>DISCHARGE RATES AT VARIOUS PRESSURES (gallons per minute)</i>				
<i>Pressure</i>		<i>Hole Diameter</i>		
<i>Per Foot of Water</i>	<i>Per Square Inch</i>	<i>3/8 Inch</i>	<i>7/16 Inch</i>	<i>1/2 Inch</i>
<i>1</i>	<i>0.43</i>	<i>1.66</i>	<i>2.26</i>	<i>2.95</i>
<i>2</i>	<i>0.87</i>	<i>2.34</i>	<i>3.19</i>	<i>4.17</i>
<i>3</i>	<i>1.30</i>	<i>2.87</i>	<i>3.91</i>	<i>5.10</i>
<i>4</i>	<i>1.73</i>	<i>3.31</i>	<i>4.51</i>	<i>5.89</i>
<i>5</i>	<i>2.17</i>	<i>3.71</i>	<i>5.04</i>	<i>6.59</i>

5. Friction losses in schedule 40 plastic pipe are listed in the following table:

<i>FRICITION LOSS IN SCHEDULE 40 PLASTIC PIPE; C = 150 (ft per 100 ft)</i>	
	<i>Pipe Diameter (inches)</i>

<i>Flow in gallons per minute</i>	<i>1</i>	<i>1 1/4</i>	<i>1 1/2</i>	<i>2</i>	<i>3</i>	<i>4</i>	<i>6</i>	<i>8</i>	<i>10</i>
<i>1</i>	<i>0.07</i>								
<i>2</i>	<i>0.28</i>	<i>0.07</i>							
<i>3</i>	<i>0.60</i>	<i>0.16</i>	<i>0.07</i>						
<i>4</i>	<i>1.01</i>	<i>0.25</i>	<i>0.12</i>						
<i>5</i>	<i>1.52</i>	<i>0.39</i>	<i>0.18</i>						
<i>6</i>	<i>2.14</i>	<i>0.55</i>	<i>0.25</i>	<i>0.07</i>					
<i>7</i>	<i>2.89</i>	<i>0.76</i>	<i>0.36</i>	<i>0.10</i>					
<i>8</i>	<i>3.63</i>	<i>0.97</i>	<i>0.46</i>	<i>0.14</i>					
<i>9</i>	<i>4.57</i>	<i>1.21</i>	<i>0.58</i>	<i>0.17</i>					
<i>10</i>	<i>5.50</i>	<i>1.46</i>	<i>0.70</i>	<i>0.21</i>					
<i>11</i>		<i>1.77</i>	<i>0.84</i>	<i>0.25</i>					
<i>12</i>		<i>2.09</i>	<i>1.01</i>	<i>0.30</i>					
<i>13</i>		<i>2.42</i>	<i>1.17</i>	<i>0.35</i>					
<i>14</i>		<i>2.74</i>	<i>1.33</i>	<i>0.39</i>					
<i>15</i>		<i>3.06</i>	<i>1.45</i>	<i>0.44</i>	<i>0.07</i>				
<i>16</i>		<i>3.49</i>	<i>1.65</i>	<i>0.50</i>	<i>0.08</i>				
<i>17</i>		<i>3.93</i>	<i>1.86</i>	<i>0.56</i>	<i>0.09</i>				
<i>18</i>		<i>4.37</i>	<i>2.07</i>	<i>0.62</i>	<i>0.10</i>				
<i>19</i>		<i>4.81</i>	<i>2.28</i>	<i>0.68</i>	<i>0.11</i>				
<i>20-24</i>		<i>5.23</i>	<i>2.46</i>	<i>0.74</i>	<i>0.12</i>				

<b><i>FRICTION LOSS IN SCHEDULE 40 PLASTIC PIPE; C = 150 (ft per 100 ft)</i></b>									
	<b><i>Pipe Diameter (inches)</i></b>								
<b><i>Flow in gallons per minute</i></b>	<b><i>1</i></b>	<b><i>1 1/4</i></b>	<b><i>1 1/2</i></b>	<b><i>2</i></b>	<b><i>3</i></b>	<b><i>4</i></b>	<b><i>6</i></b>	<b><i>8</i></b>	<b><i>10</i></b>
<b><i>25-29</i></b>			<b><i>3.75</i></b>	<b><i>1.10</i></b>	<b><i>0.16</i></b>				
<b><i>30-34</i></b>			<b><i>5.22</i></b>	<b><i>1.54</i></b>	<b><i>0.23</i></b>				
<b><i>35-39</i></b>				<b><i>2.05</i></b>	<b><i>0.30</i></b>	<b><i>0.07</i></b>			
<b><i>40-44</i></b>				<b><i>2.62</i></b>	<b><i>0.39</i></b>	<b><i>0.09</i></b>			
<b><i>45-49</i></b>				<b><i>3.27</i></b>	<b><i>0.48</i></b>	<b><i>0.12</i></b>			
<b><i>50-59</i></b>				<b><i>3.98</i></b>	<b><i>0.58</i></b>	<b><i>0.16</i></b>			
<b><i>60-69</i></b>					<b><i>0.81</i></b>	<b><i>0.21</i></b>			
<b><i>70-79</i></b>					<b><i>1.08</i></b>	<b><i>0.28</i></b>			
<b><i>80-89</i></b>					<b><i>1.38</i></b>	<b><i>0.37</i></b>			
<b><i>90-99</i></b>					<b><i>1.73</i></b>	<b><i>0.46</i></b>			
<b><i>100-149</i></b>					<b><i>2.09</i></b>	<b><i>0.55</i></b>	<b><i>0.07</i></b>		
<b><i>150-199</i></b>						<b><i>1.17</i></b>	<b><i>0.16</i></b>		
<b><i>200-249</i></b>							<b><i>0.28</i></b>	<b><i>0.07</i></b>	
<b><i>250-299</i></b>							<b><i>0.41</i></b>	<b><i>0.11</i></b>	
<b><i>300-349</i></b>							<b><i>0.58</i></b>	<b><i>0.16</i></b>	
<b><i>350-399</i></b>							<b><i>0.78</i></b>	<b><i>0.20</i></b>	<b><i>0.07</i></b>
<b><i>400-449</i></b>							<b><i>0.99</i></b>	<b><i>0.26</i></b>	<b><i>0.09</i></b>
<b><i>450-499</i></b>							<b><i>1.22</i></b>	<b><i>0.32</i></b>	<b><i>0.11</i></b>

<b><i>FRICTION LOSS IN SCHEDULE 40 PLASTIC PIPE; C = 150 (ft per 100 ft)</i></b>									
	<b><i>Pipe Diameter (inches)</i></b>								
<b><i>Flow in gallons per minute</i></b>	<b><i>1</i></b>	<b><i>1 1/4</i></b>	<b><i>1 1/2</i></b>	<b><i>2</i></b>	<b><i>3</i></b>	<b><i>4</i></b>	<b><i>6</i></b>	<b><i>8</i></b>	<b><i>10</i></b>
<b><i>500-599</i></b>								<b><i>0.38</i></b>	<b><i>0.14</i></b>
<b><i>600-699</i></b>								<b><i>0.54</i></b>	<b><i>0.18</i></b>
<b><i>700-799</i></b>								<b><i>0.72</i></b>	<b><i>0.24</i></b>
<b><i>800-899</i></b>									<b><i>0.32</i></b>
<b><i>900-999</i></b>									<b><i>0.38</i></b>
<b><i>1000 or more</i></b>									<b><i>0.46</i></b>

***6. Distribution pipes in the pressure distribution system must be looped.***

***7. Lateral distribution pipes must be spaced so that they are not less than 4 feet or more than 6 feet apart. The outside laterals must be placed at a distance from the perimeter of the absorption area that is equal to one-half of the distance between the lateral distribution pipes.***

***8. Manifold diameters for various manifold lengths, number of laterals and lateral discharge rates for plastic pipe are shown in the following diagram:***

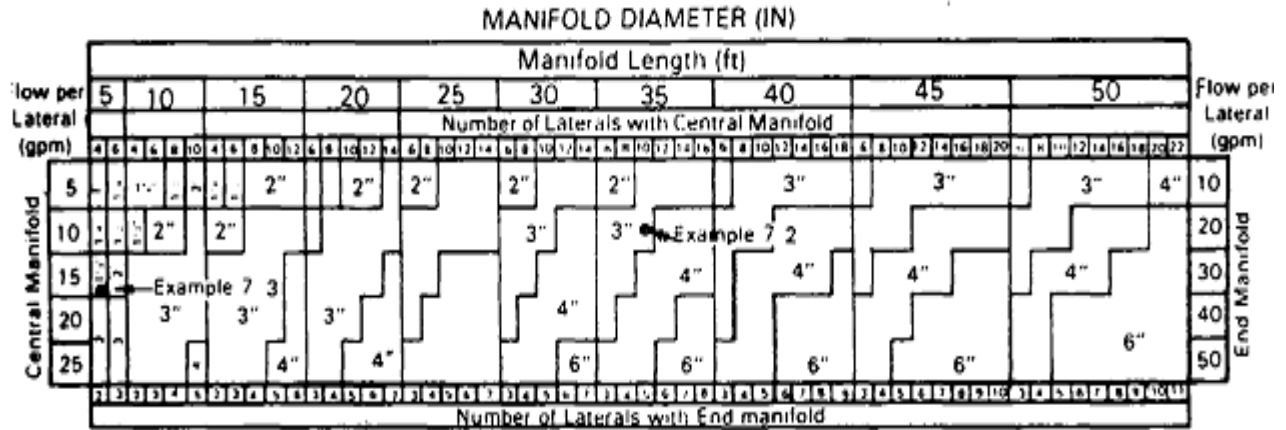

<sup>a</sup> Computed for plastic pipe only. The Hazen-Williams equation was used to compute headlosses through each segment (Hazen-Williams C = 150). The maximum manifold length for a given lateral discharge rate and spacing was defined as that length at which the difference between the heads at the distal and supply ends of the manifold exceeded 10 percent of the head at the distal end.

9. *The required lateral pipe diameters for various hole diameters, hole spacings and lateral lengths for plastic pipe are shown in the following diagram:*

REQUIRED LATERAL PIPE DIAMETERS FOR VARIOUS HOLE DIAMETERS, HOLE SPACINGS, AND LATERAL LENGTHS<sup>a</sup>  
(FOR PLASTIC PIPE ONLY)

Lateral Length (ft)	LATERAL DIAMETER (IN)																																			
	Hole Diameter (in)							Hole Diameter (in)							Hole Diameter (in)							Hole Diameter (in)							Hole Diameter (in)							
	1/4							5/16							3/8							7/16							1/2							
	Hole Spacing (ft)							Hole Spacing (ft)							Hole Spacing (ft)							Hole Spacing (ft)							Hole Spacing (ft)							
	2	3	4	5	6	7	2	3	4	5	6	7	2	3	4	5	6	7	2	3	4	5	6	7	2	3	4	5	6	7	2	3	4	5	6	7
10	1"							1"							1"							1"							1"							
15	1"							1"							1"							1"							1"							
20	1"							1"							1"							1"							1"							
25	1"							1"							1"							1"							1"							
30	1"							1"							1"							1"							1"							
35	1"							1"							1"							1"							1"							
40	1"							1"							1"							1"							1"							
45	1"							1"							1"							1"							1"							
50	1"							1"							1"							1"							1"							

<sup>a</sup> Computed for plastic pipe only. The Hazen-Williams equation was used to compute headlosses through each pipe segment (Hazen-Williams C= 150). The orifice equation for sharp-edged orifices (discharge coefficient = 0.6) was used to compute the discharge rates through each orifice. The maximum lateral length for a given hole and spacing was defined as that length at which the difference between the rates of discharge from the distal end and the supply end orifice reached 10 percent of the distal end orifice discharge rate.

Sec. 83. 1. *The installation of a holding tank system for domestic sewage requires a permit. The Division or other administrative authority may issue a permit for a site that meets all of the following conditions:*

- (a) The site cannot be approved for installation of a standard subsurface disposal system.*
- (b) A public or community sewerage system is not available or expected to be available within 5 years after completion of the site.*
- (c) The holding tank is intended to serve a county, state or national park, or an occasional-use facility, including, without limitation, a county fair or rodeo, or the holding tank is under the control of a city or other legal entity authorized to construct, operate and maintain a public or community sewerage system.*

*(d) The projected daily sewage flow is not more than 500 gallons, unless otherwise allowed by the Division or other administrative authority.*

*(e) The setbacks required pursuant to section 62 of this regulation can be met.*

*(f) Only domestic sewage will be discharged into the holding tank.*

*2. At all times that a holding tank permitted pursuant to this section is being used, the holder of the permit must maintain a service contract with a septic tank pumping contractor who has been issued a permit under chapter 444 of NAC to provide regular inspection and pumping of the holding tank.*

*3. Except as otherwise provided in subsections 5 and 6, a holding tank for which a permit is issued pursuant to this section must comply with the following requirements:*

*(a) Plans and specifications for each proposed holding tank must be submitted to the Division or other administrative authority for review and approval.*

*(b) Each tank must:*

*(1) Have a minimum liquid capacity of 2,000 gallons;*

*(2) Comply with the tank standards established by the Division;*

*(3) Be located and designed to facilitate the removal of its contents by pumping;*

*(4) Be equipped with both an audible and a visual alarm, placed in locations acceptable to the Division or other administrative authority, to indicate when the tank is 75 percent full;*

*(5) Have no overflow vent at an elevation lower than the overflow level of the lowest fixture served; and*

*(6) Be designed for anti-buoyancy if test-hole examination or other observations indicate that seasonally high groundwater may float the tank when empty.*

*4. An application for a permit for installation of a holding tank must include:*

*(a) A copy of a contract with a septic tank pumping contractor who has been issued a permit under chapter 444 of NAC that requires the tank to be inspected and pumped at regular intervals or as needed and the contents to be treated in a manner and at a facility approved by the Division or other administrative authority; and*

*(b) Evidence that the owner or operator of the proposed treatment facility will accept the pumpings for treatment.*

*5. Portable holding tanks may be temporarily placed at the site of limited-duration events, including, without limitation, construction projects, if the following requirements are met:*

*(a) The tank must be owned and serviced by a septic tank pumping contractor who has been issued a permit under chapter 444 of NAC.*

*(b) Tank placement and use must comply with all applicable local planning, building and health requirements.*

*(c) Only domestic sewage may be discharged into the tank.*

*(d) The tank must be maintained in a sanitary manner to prevent a health hazard or nuisance.*

*(e) The tank must not be buried, unless approved by the Division or other administrative authority.*

*(f) The tank may not be used to service a dwelling, a recreational vehicle or any other structure having sleeping accommodations, except that a tank may be used on a construction site to serve a contractor's job shack or night watchman's trailer.*

*6. In addition to the provisions of subsection 5, a portable holding tank that is temporarily placed pursuant to that subsection must meet the following standards:*



*(a) Tank capacity must not exceed 1,000 gallons unless approved by the Division or other administrative authority.*

*(b) The tank must be watertight and have no overflow vent lower than the overflow level of the lowest fixture served.*

*(c) The tank must be structurally sound and made of durable, noncorrosive materials.*

*(d) The tank must be designed and constructed to provide a secure, watertight connection with the sewer pipe for any building to which the tank is connected.*

*(e) The tank must be marked with the name and phone number of the septic tank pumping contractor who has been issued a permit under chapter 444 of NAC and who is responsible for maintaining the tank.*

**Sec. 84. 1.** *A cluster system may be installed when lot sizes, location or other site conditions make conventional sewage disposal unacceptable and when a local governing agency or its recognized entity, as listed in subsection 1 of NAC 445A.231, assumes responsibility for the operation and maintenance of a cluster system and the obtaining of a permit for the cluster system from the Division or other administrative authority.*

*2. A cluster system approved pursuant to this section must obtain an individual permit pursuant to section 45 of this regulation which must be issued by the Division or other administrative authority to the local governing body or its recognized entity, as listed in subsection 1 of NAC 445A.231, which is responsible for the cluster system.*

*3. Cluster systems must be designed and constructed in accordance with the requirements of sections 3 to 89, inclusive, of this regulation. A cluster system must be maintained in accordance with the requirements of the individual permit issued for that cluster system.*

*4. The tank size of a cluster system must not exceed 25,000 gallons, and the amount of sewage flow from the tank must not exceed the limits of subsection 2 of section 45 of this regulation.*

**Sec. 85.** *1. A draft operations and maintenance manual for an on-site sewage disposal system must be submitted together with the design specifications pursuant to section 52 of this regulation. A final version of the manual, which is stamped, signed and dated by the design engineer, must be submitted together with the certificate of completion required pursuant to section 54 of this regulation.*

*2. The type and size of an on-site sewage disposal system determine the extent of operations and maintenance activities required for the system. The manual must include, without limitation, procedures and schedules for the following:*

*(a) Response to emergencies, including, without limitation, notification of users, the Division or other administrative authority and, if necessary, the appropriate local health authority.*

*(b) Reporting the cause of any failure or malfunction in writing to the Division or other administrative authority.*

*(c) Making any repairs, replacements or modifications of design that are required to restore the system to proper operation.*

*(d) Inspection of facilities to ascertain operational efficiency and the general condition of equipment, using a checklist.*

*(e) Pumping of septic tanks, pump or siphon chambers, or other storage or treatment tanks by a septic tank pumping contractor who has been issued a permit under chapter 444 of NAC*

*and periodic pumping and maintenance of other pretreatment mechanisms by qualified persons approved by the Division or other administrative authority.*

*(f) Maintenance of pumps, motors and switches.*

*(g) Replacement of worn or damaged equipment.*

*(h) Monitoring of water usage and generation of wastewater.*

*(i) Dosing and resting cycles for the drain field, if applicable.*

*(j) Determining water levels in trenches or other drain fields.*

*(k) Monitoring of groundwater quality and adjacent surface water quality, if necessary.*

*(l) Other activities as determined by the design engineer.*

*(m) Sample forms for all operations and maintenance activities.*

*3. Records must be kept of all operations and maintenance activities, including, without limitation, inspections, monitoring, work performed and conditions found. The records must be available for inspection by the Division or other administrative authority at all times.*

*Annual summary reports of the operation and maintenance of the on-site sewage disposal system must be submitted to the Division or other administrative authority as required by the permit pursuant to section 60 of this regulation.*

*4. If the operation and maintenance of an on-site sewage disposal system is performed by a municipality or other entity operating multiple systems, a general manual with specific requirements for specific systems is acceptable for the purposes of this section.*

**Sec. 86. 1.** *An owner or operator of an on-site sewage disposal system must decommission the on-site sewage disposal system if:*

*(a) A community or public sewerage system becomes available and the buildings that the on-site sewage disposal system serves are connected to that sewerage system;*

*(b) The source of sewage to the on-site sewage disposal system is permanently eliminated;*

*(c) The on-site sewage disposal system is operated in violation of any chapter of NRS or sections 3 to 89, inclusive, of this regulation and an approval to repair and a certificate of completion of the repair have not subsequently been issued for the system;*

*(d) The on-site sewage disposal system has been constructed, installed, altered or repaired without a permit required pursuant to sections 3 to 89, inclusive, of this regulation and a permit has not subsequently been issued for the system; or*

*(e) The on-site sewage disposal system has been operated or used without a required certificate of completion or authorization notice from the Division or other administrative authority and a certificate of completion or authorization notice by the Division or other administrative authority has not subsequently been issued for the system.*

*2. In decommissioning an on-site sewage disposal system, the owner or operator of the system must:*

*(a) Ensure that all tanks containing septage are pumped by a septic tank pumping contractor who has been issued a permit under chapter 444 of NAC.*

*(b) Prevent liquid detention by ensuring that each tank containing septage:*

*(1) Has an opening in the bottom, with care taken to ensure that no person enters the tank without compliance with the confined space regulations of the United States Occupational Health and Safety Administration, 29 C.F.R. § 1910.146;*

*(2) Is filled with sand, gravel or other material approved by the design engineer; or*

*(3) Is removed and properly disposed of.*

*(c) Backfill the excavation site of any septic tank removed with material that is suitable and compatible with the intended future use of the site.*

*(d) As soon as practicable after decommissioning the on-site sewage disposal system, submit a notice of termination to the Division or other administrative authority.*

**Sec. 87. 1.** *For an on-site sewage disposal system that is under the jurisdiction of the Division, the owner must pay the following fees:*

<i>One-time application fee for a general permit to construct or make major modifications to an on-site sewage disposal system with a capacity of 5,000 gallons or more, including plan review.....</i>	<i>\$600</i>
<i>Annual fee for renewal of a general permit for an on-site sewage disposal system with a capacity of 5,000 gallons or more.....</i>	<i>\$300</i>
<i>One-time application fee for a general permit to construct or make major modifications to an on-site sewage disposal system with a capacity of less than 5,000 gallons, including plan review.....</i>	<i>\$200</i>
<i>Annual fee for renewal of a general permit for an on-site sewage disposal system with a capacity of less than 5,000 gallons .....</i>	<i>No Fee</i>
<i>To add an existing on-site sewage disposal system with a capacity of less than 5,000 gallons to a general permit.....</i>	<i>No Fee</i>
<i>One-time application fee for an individual permit to construct or make major modifications to an on-site sewage disposal system, including plan review .....</i>	<i>\$1,000</i>

*Annual fee for renewal of an individual permit for an on-site sewage disposal system..... \$1,000*

*To extend an individual or general permit to construct an on-site sewage disposal system for a 1-year period after the expiration of the permit..... \$200*

- 2. Owners of an on-site sewage disposal system subject to an annual fee must pay the annual fee on or before the date specified in the permit.*
- 3. Fees for a permit to construct an on-site sewage disposal system must be paid when the design engineer submits the certificate of completion to the Division.*
- 4. Fees to extend a permit to construct an on-site sewage disposal system must be paid at the time the request for an extension is submitted to the Division.*

*Sec. 88. 1. A person who owns or operates an on-site sewage disposal system in violation of any applicable provision of sections 3 to 89, inclusive, of this regulation or the provisions of the applicable permit issued by the Division or other administrative authority may be subject to an enforcement action pursuant to NRS 445A.675 and 445A.690 to 445A.705, inclusive.*

- 2. Violations of a permit may include, without limitation:*
  - (a) Failure to collect, analyze and report sampling results.*
  - (b) Submission of any misleading or inaccurate information relating to the on-site sewage disposal system to the Division or other administrative authority.*
  - (c) Submission of any fraudulent information to the Division or other administrative authority, including, without limitation:*

- (1) Measurements or test results for which measurements or tests were not conducted;*
- (2) Measurements or test results obtained by deliberately and knowingly making measurements or collecting test samples at times and places other than those specified in the permit or in sections 3 to 89, inclusive, of this regulation; or*
- (3) Test results obtained through the use of unapproved or erroneous procedures for sampling, preservation, storage or analysis.*

**Sec. 89.** *1. All on-site sewage disposal systems that are in operation before August 26, 2008, may request, by submitting a notice of intent to continue operation, a general or individual permit, as applicable, from the Division or other administrative authority to continue operation until:*

- (a) The system fails pursuant to section 55 of this regulation;*
- (b) Groundwater is affected by the system;*
- (c) Expansion or alteration of the system is proposed; or*
- (d) A public or community sewerage system is available.*

*2. If any circumstance specified in paragraph (a), (b) or (c) of subsection 1 occurs, the owner or operator of the system must obtain the services of a design engineer to evaluate the system and prepare design specifications for necessary repairs or alterations to be submitted to the Division or other administrative authority pursuant to sections 49 and 52 of this regulation.*

**Sec. 90.** NAC 445A.228 is hereby amended to read as follows:

445A.228 1. Except as otherwise provided in subsection 2, a person shall not discharge a pollutant from a point source into any waters of ~~[this]~~ *the* State without obtaining a permit from the Department.

2. Although not exempted from complying with all other applicable laws, rules and regulations regarding pollution, the following are specifically exempted from the requirements to obtain a permit:

(a) Persons utilizing an individual sewage disposal system or other sewage disposal system that uses a soil absorption system for the treatment and disposal of domestic wastes, ~~with accumulative flows of less than 5,000 gallons per day, providing~~ *if* the system is approved and is installed, operated and maintained in accordance with the rules and regulations and other requirements of the district health departments, ~~or~~ the State Board of Health ~~or~~ *the Division or other administrative authority, as authorized by sections 3 to 89, inclusive, of this regulation, as applicable.* This exemption does not preclude the possibility that health authorities, *the Division or other administrative authority* will require permits.

(b) Except as otherwise provided in this paragraph, persons discharging pollutants into a publicly owned or privately owned sewerage system, if the owner of such sewerage system has a valid permit from the Department. In such cases, the owner of the sewerage system assumes ultimate responsibility for controlling and treating the pollutants which he allows to be discharged into the system. The Department may require an industrial user who discharges pollutants into a publicly owned treatment works which does not have an approved pretreatment program to obtain a permit pursuant to NAC 445A.257.

(c) Discharges of pollutants from agricultural and silvicultural activities, including, without limitation, irrigation return flow and runoff from orchards, cultivated crops, pastures, rangelands and forest lands, except that this exemption does not apply to the following:

(1) Discharges from facilities in which crops, vegetation, forage growth or postharvest residues are not sustained in the normal growing season and that confine animals if the facilities



contain, or at any time during the previous 12 months contained, for a total of 30 days or more, any of the following types of animals at or in excess of the number listed for each type of animal:

- (I) Cattle, veal calves or a pair consisting of a cow and a calf, 1,000;
- (II) Mature dairy cattle (whether milkers or dry cows), 700;
- (III) Swine weighing over 55 pounds, 2,500;
- (IV) Swine weighing 55 pounds or less, 10,000;
- (V) Horses, 500;
- (VI) Sheep or lambs, 10,000;
- (VII) Turkeys, 55,000;
- (VIII) Chickens, if the animal confinement facility has a liquid manure handling system, 30,000;
- (IX) Chickens, other than laying hens, if the animal confinement facility does not have a liquid manure handling system, 125,000;
- (X) Laying hens, if the animal confinement facility does not have a liquid manure handling system, 82,000;
- (XI) Ducks, if the animal confinement facility has a liquid manure handling system, 5,000; or
- (XII) Ducks, if the animal confinement facility does not have a liquid manure handling system, 30,000.

- (2) Discharges from production facilities for aquatic animals.
- (3) Discharges of irrigation return flow , ~~H~~ such as tailwater, tile drainage, surfaced groundwater flow or bypass water , ~~H~~ operated by public or private organizations or natural persons if the source of water is effluent from a treatment works.

(4) Discharges from any agricultural or silvicultural activity which have been identified by the Administrator or the Director as a significant contributor of pollution.

**Sec. 91.** NAC 445A.842 is hereby amended to read as follows:

445A.842 NAC 445A.810 to 445A.925, inclusive, apply to any person proposing to construct, alter, repair or abandon any injection well, or owning, using or operating, or proposing to use or operate any injection well on any lands within this State except for ~~any~~:

*1. Any injection well which is constructed or operated on land, whether tribal or allotted, within the limits of any Indian reservation or dependent Indian colony under the jurisdiction of the Federal Government ~~is~~; or*

*2. Any on-site sewage disposal system as defined in section 31 of this regulation.*

**Sec. 92.** NAC 445A.849 is hereby amended to read as follows:

445A.849 A Class V well is any injection well not included in Classes I, II, III and IV, including, without limitation:

1. Wells used to inject the water for heating or cooling by a heat pump;
2. Cesspools or other devices receiving wastes which have an open bottom and sometimes have perforated sides;
3. Wells used to inject water previously used for cooling;
4. Wells used to drain surface fluid, primarily the runoff from storms, into a subsurface formation;
5. Wells used for the injection of fluids accumulated from dewatering operations;
6. Drywells and wells used for the injection of nonhazardous wastes into a subsurface formation;
7. Wells used to replenish the water in an aquifer;

8. Wells used to inject water into an aquifer of fresh water to prevent the intrusion of water of a lower quality into the fresh water;

9. Wells used to inject a mixture of water and sand, mill tailings or other solids into subsurface mines;

10. Wells used to inject ~~[sanitary waste]~~ *domestic sewage* for facilities other than single-family residences ~~[or facilities]~~ *and* having a volume capacity of ~~[less]~~ *more* than ~~[5,000]~~ *3,000* gallons per day ~~;~~ *which are regulated as on-site sewage disposal systems pursuant to sections 3 to 89, inclusive, of this regulation;*

11. Wells used to inject fluids into a zone, other than an oil or gas producing zone, to reduce or eliminate subsidence associated with the overdraft of fresh water;

12. Wells used for the storage of hydrocarbons in a gaseous state at standard temperature and pressure;

13. Geothermal injection wells used in contact and noncontact heating and aquaculture, and in the production of energy;

14. Wells used for solution mining of ores or minerals in conventional mines, such as stopes leaching;

15. Wells used to inject spent brine into the same formation from which it was withdrawn after extraction of halogens or their salts;

16. Injection wells used in experimental technologies;

17. Injection wells that are approved under a federal or state cleanup program and used to reinject pumped and treated contaminated groundwater, other than hazardous waste, back into the same formation;

18. Injection wells used to inject fluids for the chemical or microbiological treatment of contaminated groundwater or soil; and

19. Motor vehicle waste disposal wells.